

Dual

Edition February 1972

Dual 1215 S Service Manual



Technical data

Power supply
Power supply voltage
Drive
Power consumption
Current drain
Turntable platter
Turntable speeds
Pitch control variation
Speed accuracy deviation
to DIN 45 500
Rumble
Weighted rumble
Tonearm

Maximum tracking error
Cartridge holder

Weight
Dimensions and mounting
cutouts

alternating, 50 or 60 cycle changeable by changing motor pulley
110/117 and 220/240 V, switchable
4-pole asynchronous pole motor with radialelastic suspension
 ≤ 10 watts
115 ma approx. at 117 V, 60 cycle
weighing 3,2 lbs., dia 10 5/8 inch,
33 1/3, 45 and 78 r.p.m.,
adjustment range of approx. 1 semitone (6 %) at all three turntable speeds

< 0.15 % with platter 3,2 lbs.

≥ 35 dB below signal level in accordance to DIN 45 500

≥ 55 dB below signal level in accordance to DIN 45 500

torsionally rigid, aluminium tubular tonearm with vertical needle bearings,
horizontal 2-layer precision ball bearings
0,18°/cm

removable, suitable for acceptance of cartridges having 1/2" mounting and
possessing a weight of 1 – 9 grams.

aprox. 9,7 lbs. with platter 3,2 lbs.

see installation instructions

Dual Gebrüder Steidinger · 7742 St. Georgen/Schwarzwald

Fig. 1 Tonearm hookup schematic

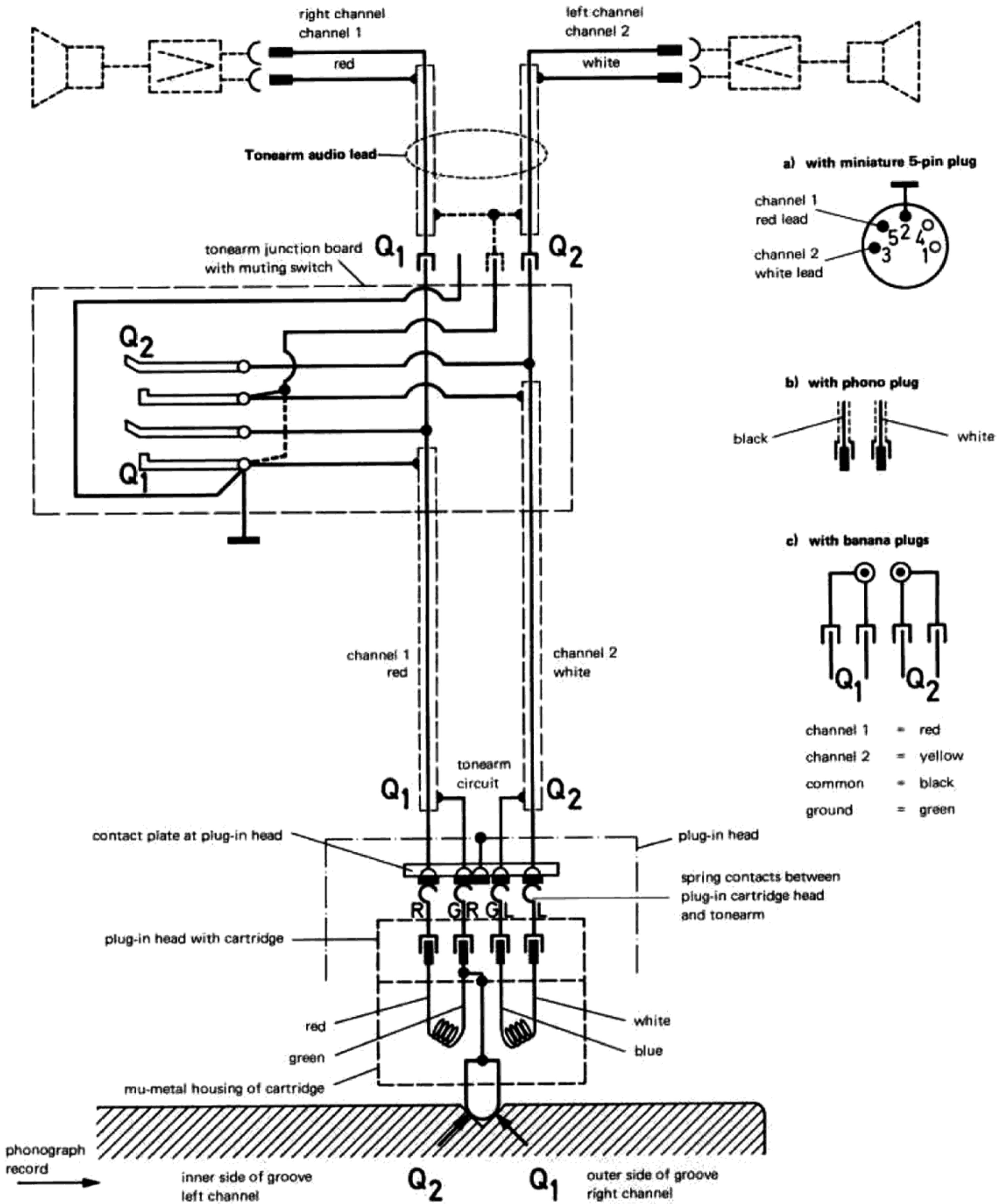

Contents

	Page
Technical data	1
Tonearm hookup schematic	2
Motor and drive	4
Pitch Control	5
Turntable does not run when unit is plugged in and "start" switch operated	5
Turntable does not come up to speed	5
Rumble in reproduction	5
Correct nominal speed obtained only at extreme settings of pitch control	5
Tonearm head is not parallel to turntable platter	5
Tonearm and tonearm bearing	6
Antiskating adjustment	7
Stylus skips	7
Tonearm sets down beside tonearm rest	7
Horizontal pivot friction too high	7
Tonearm movements	8
Tonearm lift (Cue control)	8
Tonearm misses edge of record	9
Tonearm strikes record during change cycle	9
Tonearm does not move onto record when drop cycle is started	9
Tonearm lowers too quickly when drop cycle is started	9
Tonearm returns to rest immediately after being placed on record manually	9
Start cycle	9
Manual start	10
Stop switching	10
Muting switch	11
Record drop	11
Shut-off and change cycle	11
Shut-off mechanism	12
Turntable stops after automatic setdown of the tonearm	12
Last record keeps repeating	12
Record does not drop when unit is switched to "start"	13
Record drops when unit is switched to "stop"	13
Records do not drop	13
Switch latches into "stop" position when tonearm is at rest	14
Tonearm moves with stylus force and anti-skating force at zero: a) outward, b) inward	14
During change, stop and start operations, noises from the mechanism can be heard in system speaker	14
No sound	14
Motor will not shut off when tonearm is on arm rest	14
Acoustic feedback	14
Replacement parts and exploded view	15 - 20
Lubrication	21

Fig. 2 Motor suspension and turntable drive

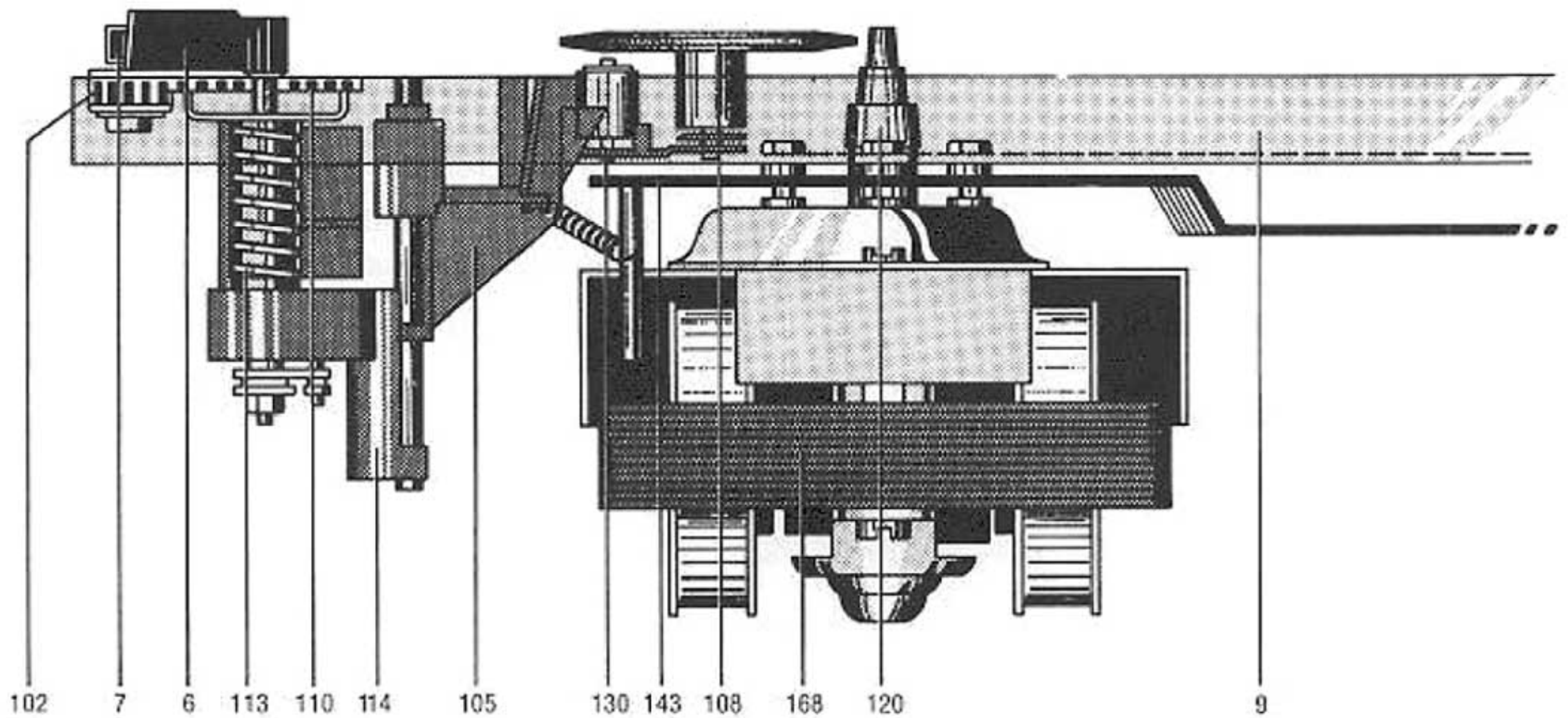

Motor and drive

The turntable platter and change mechanism are driven by a vibration-free four-pole motor (168) with an extremely low stray magnetic field.

Motor speed is constant for line-voltage variations of $\pm 10\%$. It is dependent on (and proportional to) line frequency. Two interchangeable motor pulleys (120) are available for adapting the changer to 50 or 60 Hz operation:

Motor pulley for 50 Hz operation: part no. 220 970
 Motor pulley for 60 Hz operation: part no. 220 971

The motor pulley is secured to the motor shaft by a setscrew. When a pulley is replaced or exchanged, it must be set at the correct height (see Fig. 5).

The turntable platter is driven by the idler wheel (108) which is automatically disengaged from the motor pulley when the unit is shut off, in order to protect its driving surface.

Turntable speeds of $33\frac{1}{3}$, 45 and 78 rpm are selected by raising or lowering the idler wheel (108) to the appropriate step on the motor pulley.

When the selector lever (6) is moved, the selector segment (112) rotates. This causes the lever (105) fitted in the slot of the selector segment to move in a vertical direction. The idler wheel (108) mounted on the swinging arm (130) is lifted off the motor pulley and set down again on the motor pulley step for the adjacent speed.

Fig. 3 Motor field connections (less voltage selector)

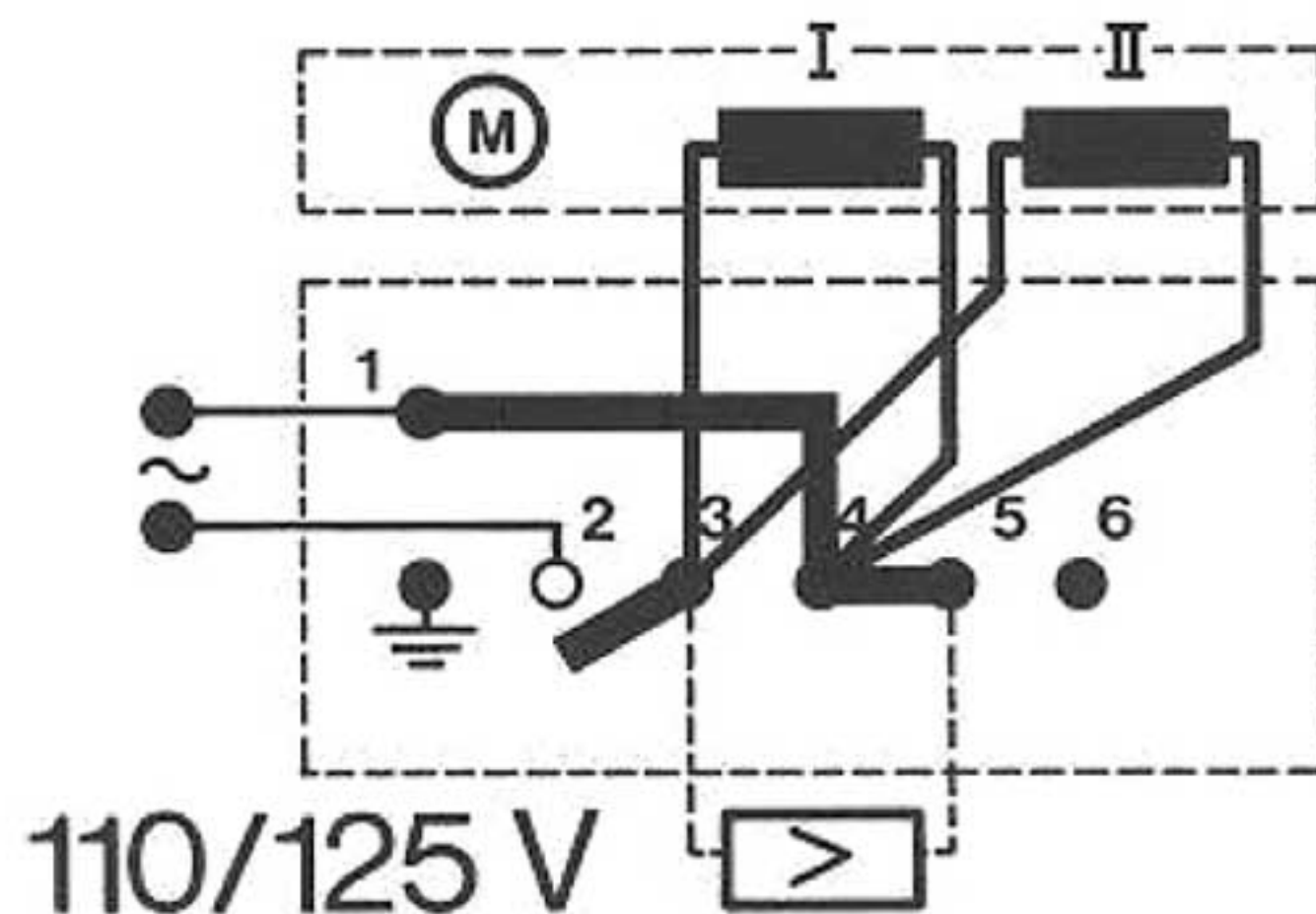
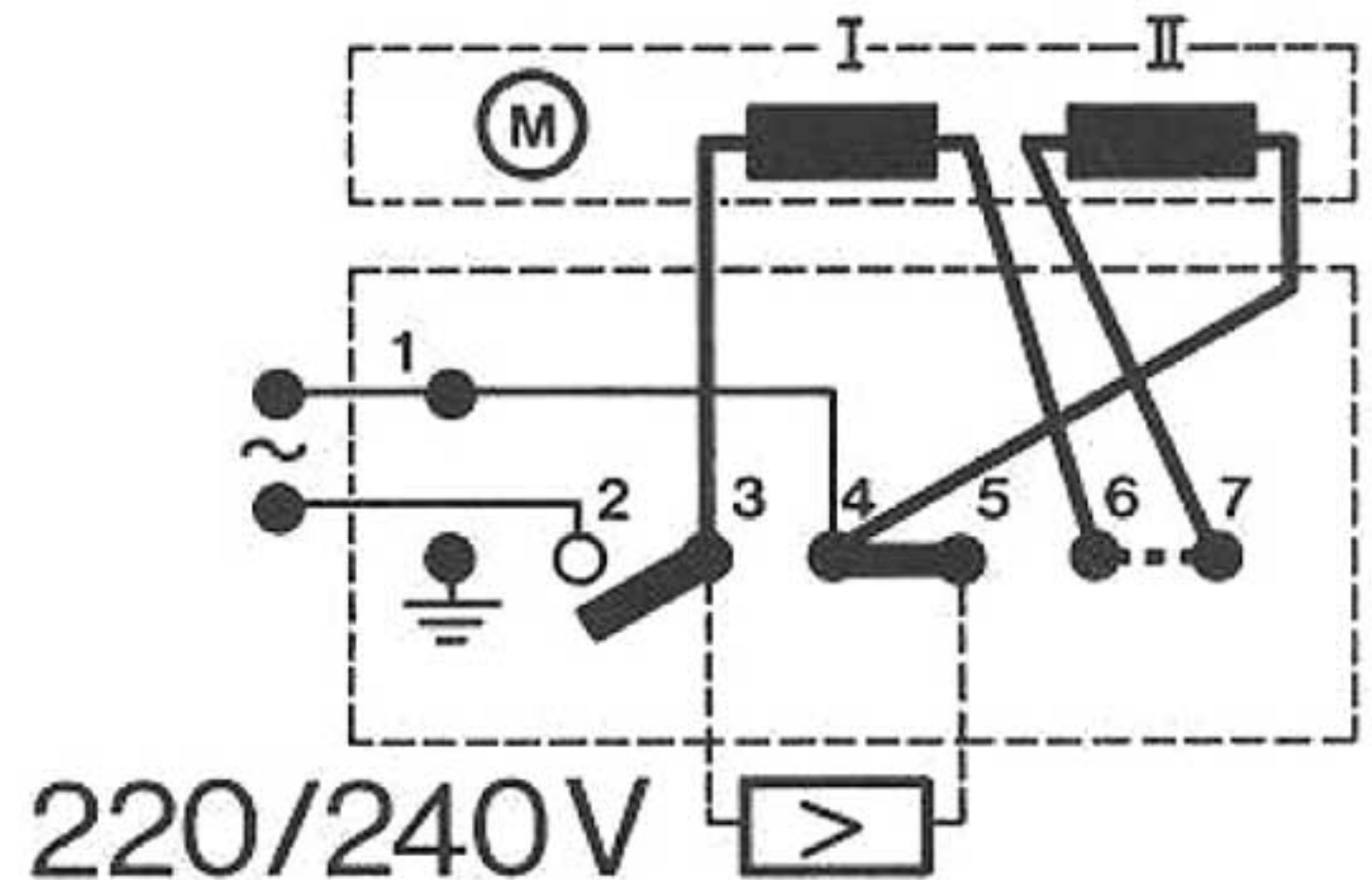

Fig. 4 Motor field connections (with voltage selector)



Pitch Control

For turntable speeds 33 1/3, 45 and 78 rpm, the unit incorporates a voltage-independent pitch control, which permits a turntable speed variation of up to 6 % (approximately one semitone).

When the pitch control knob (7) is turned, the switch segment (112) and the switch lever (105) attached to it are moved up or down. This vertical displacement changes the position of the idler wheel on whatever step of the motor pulley it has been placed on (by the speed selector), and, due to the tapered shape of the pulley, effects approximately $\pm 3\%$ variation in speed.

Fig. 5 Motor pulley position

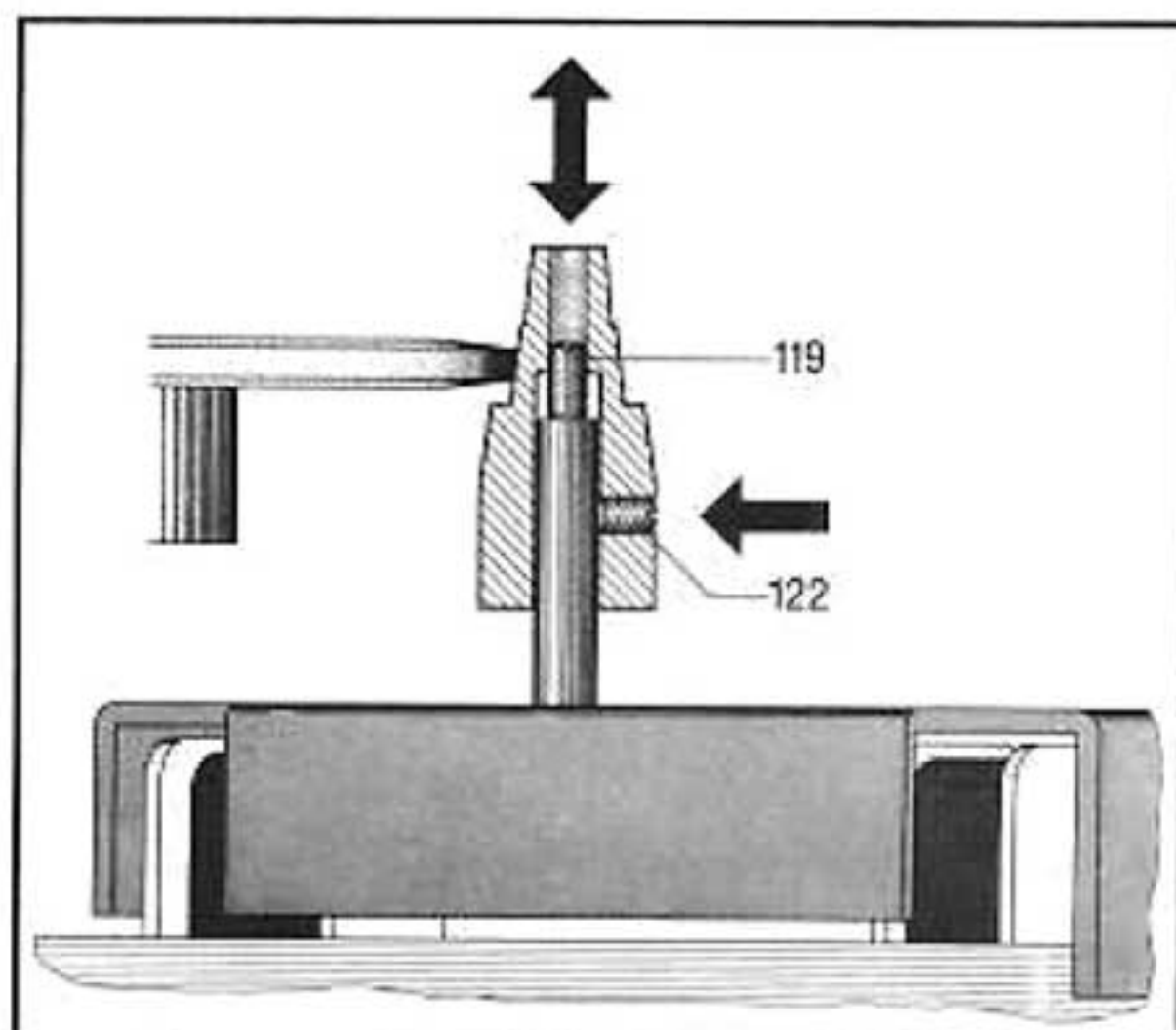

Symptom	Cause	Remedy
Turntable does not run when unit is plugged in and start switch operated	<ul style="list-style-type: none"> a) Current path to motor interrupted b) Idler wheel (108) not in contact with platter c) Motor pulley loose 	<ul style="list-style-type: none"> a) Check connection at switch plate and voltage selector b) Check switch lever assembly (105) c) Tighten motor pulley
Turntable does not come up to speed	<ul style="list-style-type: none"> a) Motor pulley is not correct for local line frequency b) Slippage between idler wheel (108) and motor pulley (120) or platter c) Excessive friction in motor, drive wheel or platter bearings 	<ul style="list-style-type: none"> a) Change motor pulley b) Clean friction surfaces of idler wheel, motor pulley and turntable platter. If necessary, replace drive wheel. Once the drive surface of the platter has been cleaned, do not touch it with your fingers c) Clean and oil bearings
Rumble in reproduction	Worn idler wheel	Replace idler wheel (108) and clean platter drive surface and motor pulley with greaseless solvent. Once surface are cleaned, do not touch them with your fingers
Correct nominal speed obtained only at extreme settings of pitch control	Idler wheel does not contact motor pulley correctly	Loosen setscrew (122) and by means of setscrew (119) adjust the motor pulley on the motor shaft so that when the fine speed adjustment knob is in the center of its range, the idler wheel is positioned in the center of the appropriate motor pulley step. (Fig. 5). When adjustment is completed, tighten setscrew (122).

Symptom

Tonearm head is not parallel to turntable platter

Cause

Orientation of tonearm head on tonearm tube has altered because of jolting in transport (shipping)

Remedy

Remove turntable platter with the help of a screwdriver inserted through the hole in the chassis placed there for the purpose. Loosen screw on tonearm head. After correcting the tonearm head, tighten screw. (Fig. 6)

Fig. 6

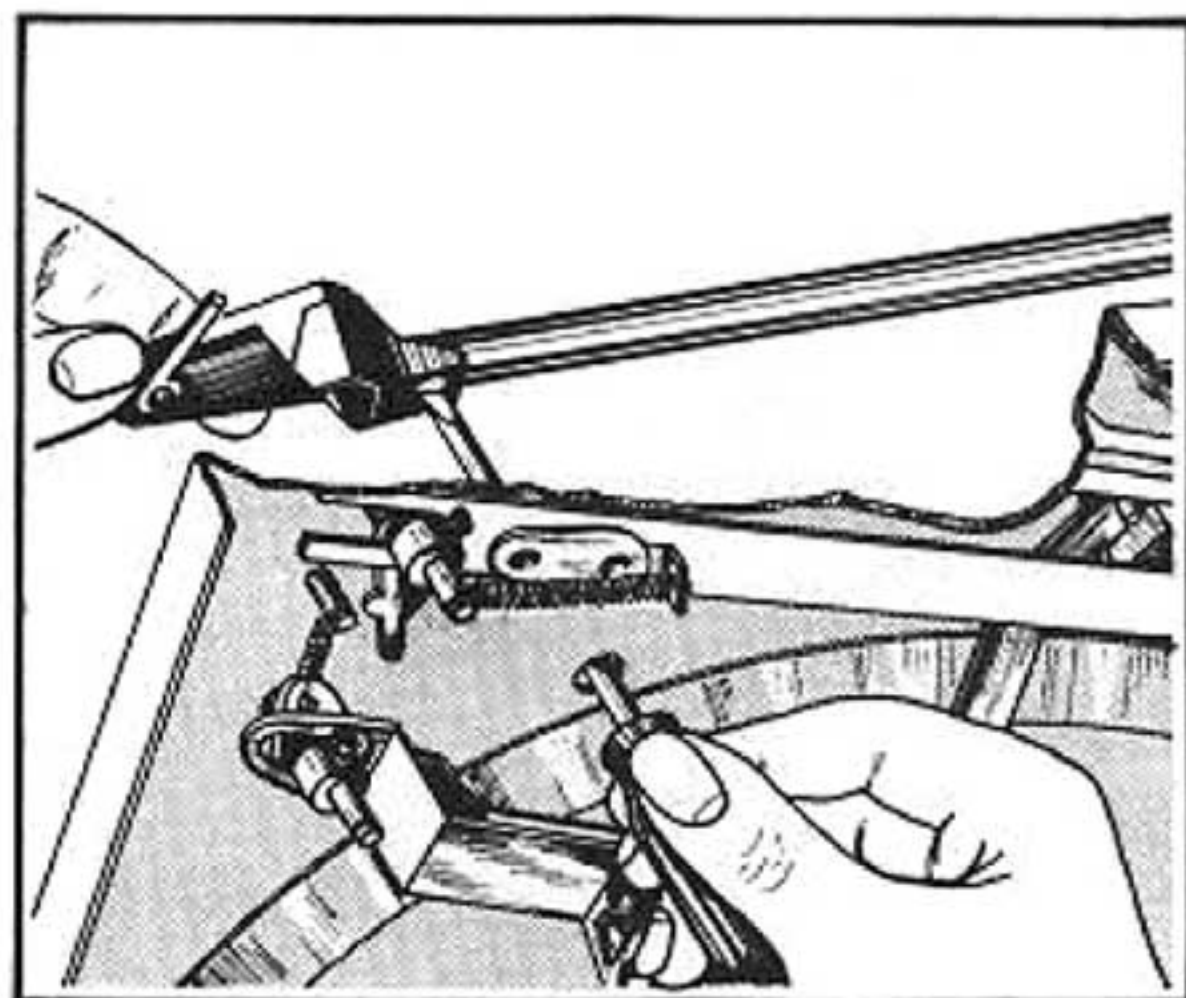

Tonearm and tonearm bearing

The tonearm of the Dual 1215 S is counterbalanced and pivots vertically and horizontally on precision ball bearings. This approach gives highly favorable tracking characteristics. The tonearm head is removable. To aid in replacing or adjusting the tonearm head, a hole is provided in the turntable base to facilitate mounting the tonearm head without first removing the tonearm. Before setting the correct stylus force for the cartridge that has been installed, the tonearm should be balanced with the stylus-force setting at zero.

It is recommended that the balancing should be done right next to the tonearm rest.

The counterweight is so designed that it can balance cartridges with weights from 1 to 9 grams.

For shock absorption (the absorption of short, rapid jolts) the counterweight is elastically mounted on the tonearm and bracked to prevent unintended rotation. The tonearm head is designed to accept all cartridges with internationally standard 1/2 inch mounting centers and with a weight not exceeding 1 - 9 grams. Stylus force is set by turning a calibrated spring housing (53), thus tensioning or slackening the spiral spring it contains. The scale is calibrated over a range of 0 to 5,5 grams, allowing an exact setting of stylus within that range in 0,5 gram steps.

Fig. 7 Tonearm bearing assembly

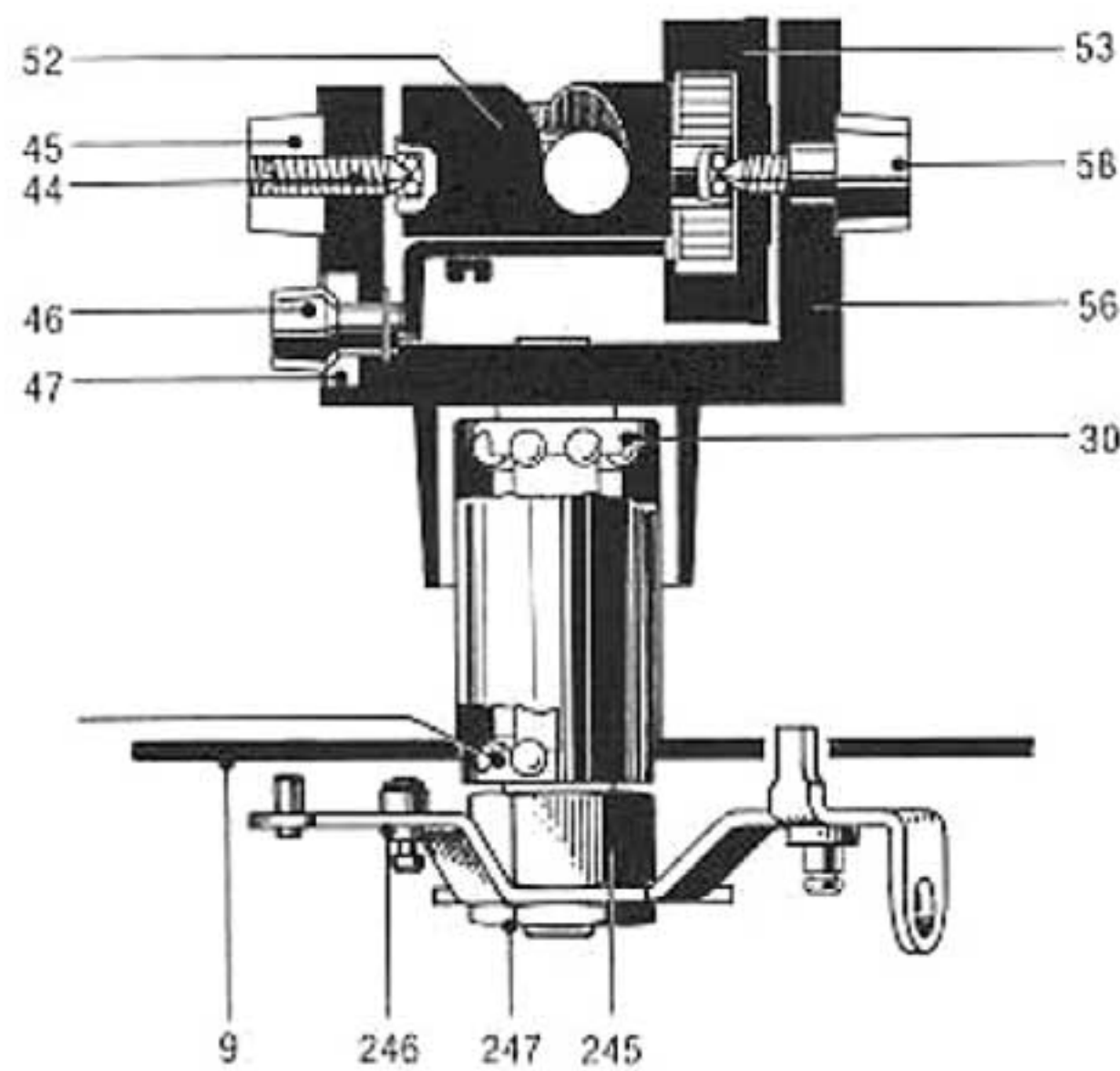
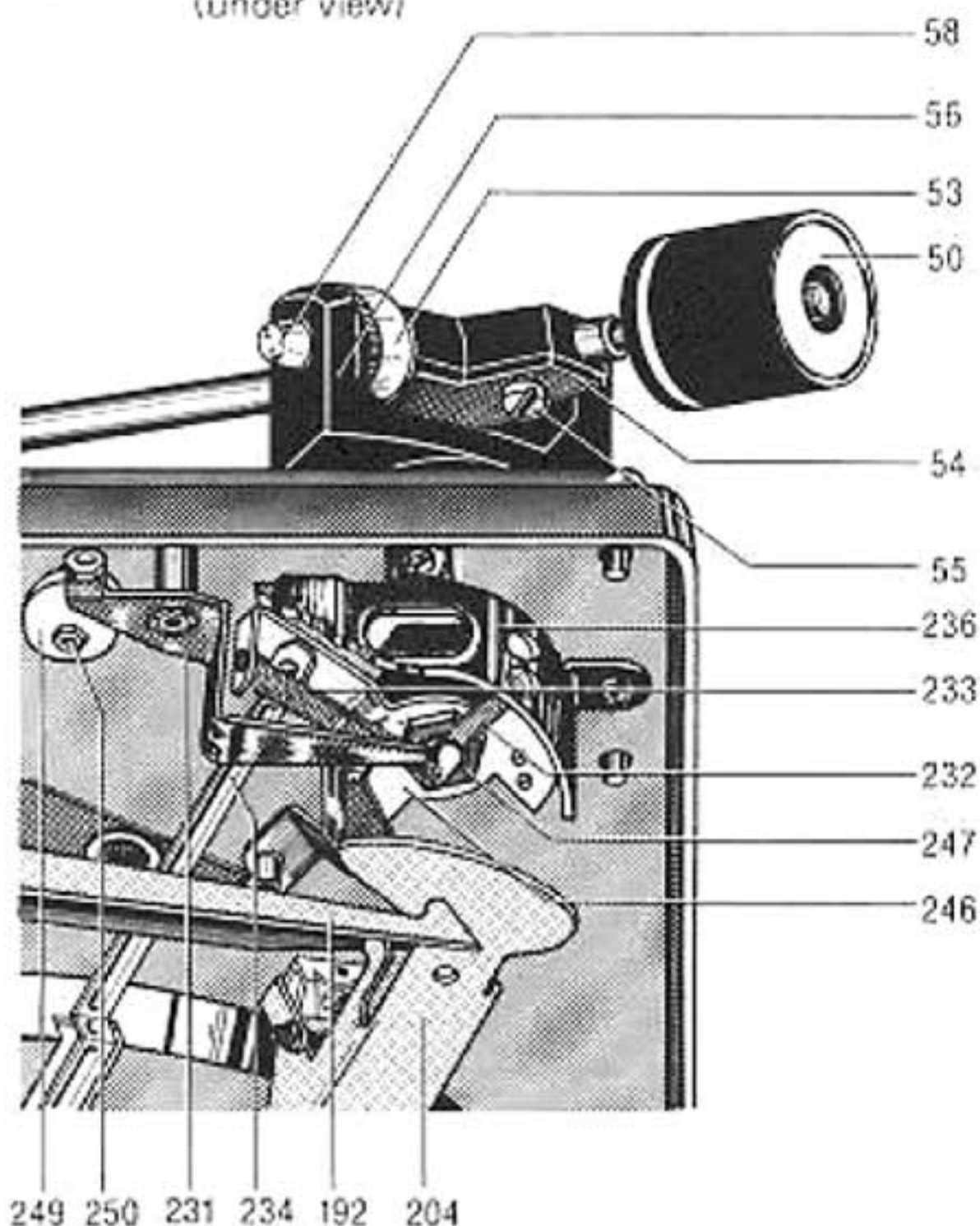

Fig. 8 Tonearm bearing assembly (under view)



To replace the tonearm with its bearing assembly, the following procedure is recommended:

1. Secure the unit in the repair jig, set the stylus force to zero and lock the tonearm in place.
2. Turn the unit upside down and unsolder the tonearm leads.
3. Remove main lever (204) and linking lever (192).
4. Connect the springs and screw on the shield.
5. Unfasten the c-washer and remove skating lever.
6. After loosening the c-washer (254) and friction washer (253) separate shutoff slide (234) four segment
7. Loosen nut (247), holding adjusting nut (245) with an SW 14 hex wrench.
8. Remove segment (246) with lift bolt (229).
9. Unscrew positioning nut (245).
10. Remove bearing race (170) with 5 balls.
11. Return unit to upright position and remove tonearm.

To reinstall the tonearm with bearing assembly, first insert the bearing race (30) with 5 balls. Then insert the tonearm and replace the lower bearing (race and 5 balls, 170). Run up positioning nut (245) lightly onto threads by hand until you feel slight resistance. Then turn it back (loosen it) by a quarter turn. Replace segment and hex nut (247). When you tighten hex nut (247) hold positioning nut (245) with a second wrench. After tightening you must still just be able to feel a slight play in the bearing.

After tightening the nuts, check the position of the tonearm over the tonearm rest. This is correct when it descends to the tonearm rest without binding.

When reinstalling the protective cover (237), be sure that the segment (246) can move without hindrance through the tonearm leads.

To remove the tonearm from its bearing frame, unsolder the tonearm leads, then set the stylus-force adjustment to zero. Unscrew locknut (45) with setscrew (44) and bearing screw (58) (left hand thread). Carefully lift the tonearm free from the bearing frame.

Anti-skating adjustment

The tendency of a tonearm with an offset (angled) head to "skate" inward across the record is eliminated in the Dual 1215 S by a precision anti-skating mechanism.

Skating force depends on tonearm geometry, stylus force and the tip radius of the stylus. The inward pull on the tonearm caused by the skating effect gives rise not only to an undesirable jumping of the tonearm when it is set down on the record, but also to unequal forces on the two opposite groove walls, with corresponding ill effects. This can be corrected with proper anti-skating adjustment.

By turning the anti-skating adjustment knob (59) on the chassis, an asymmetrical curved washer (249) is turned. This washer has two different curved surfaces corresponding, respectively, to the red and black scales on the anti-skating dial. The red scale is for conical (spherical-tip) styli; the black for elliptical (bi-radial) styli. When the knob is turned, the curved surfaces push the anti-skating lever (231) away from its rest position so that it applies a suitable counterforce via a spring (233).

Skating compensation is set at the factory for conical styli with a tip radius of 0.6 to 0.7 mil (.0006 - .0007 inch), and for elliptical styli with measurements of 0.20 to 0.23 mil by 0.79 to 0.87 mil. The hex adjusting nut is tightened and sealed. Readjustments should be attempted only with the help of the Dual Skate-O-meter and test record L 096. This work is best done by an authorized Dual service agency.

Fig. 9 Anti-skating

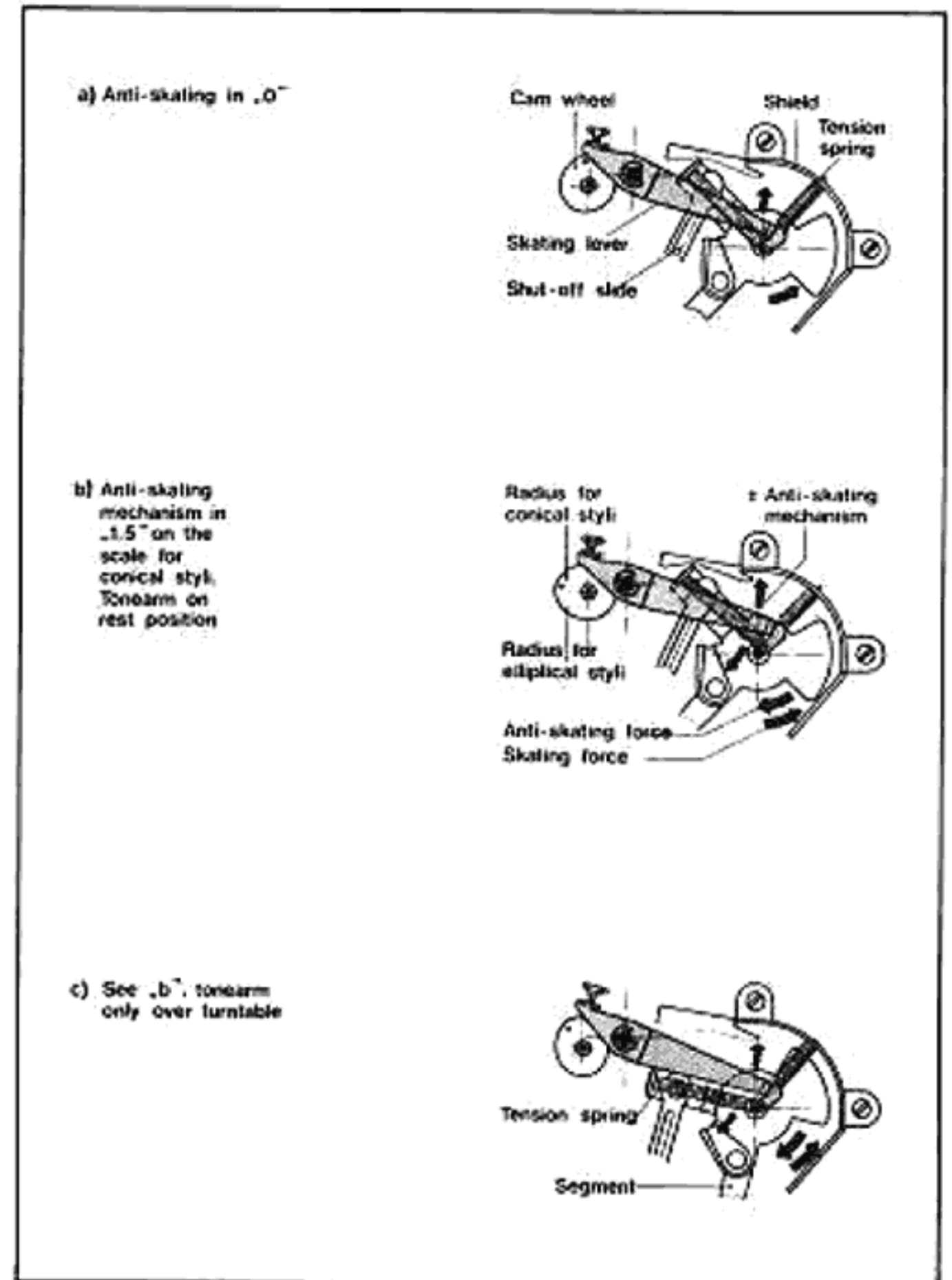

Symptom	Cause	Remedy
Stylus skips	<ul style="list-style-type: none"> a) Tonearm not balanced b) Stylus force too low c) Stylus worn or chipped d) Excessive friction in tonearm bearing e) Ball (235) missing from shut-off rail f) Anti-skating wrongly adjusted 	<ul style="list-style-type: none"> a) Balance tonearm according to operating instructions b) Set stylus force to cartridge manufacturer's recommended value c) Replace stylus d) Check tonearm horizontal pivot. Should have barely noticeable play. Adjust vertical bearing only with the left bearing screw (44) and the horizontal bearing with nut. Horizontal bearing is correctly adjusted when the tonearm, with anti-skating 0.5 p, swings freely from center to rest e) Replace ball (235) f) Correct antiskating setting
Tonearm sets down beside tonearm rest	Arm segment (246) incorrectly adjusted	Correct segment positioning: after loosening nut (247) rotate segment (246). When loosening adjusting nut (245), hold parts firmly. Adjustment is correct when the tonearm descends to the tonearm rest without binding. After adjustment, check bearing friction
Horizontal pivot friction too high	Tonearm is set too high on tonearm lift. Main lever jams against guide pin of lift screw assembly	Stylus should be no farther from record surface than 1/4". Adjust by turning screw (211)

Fig. 10 Tonearm guide mechanism

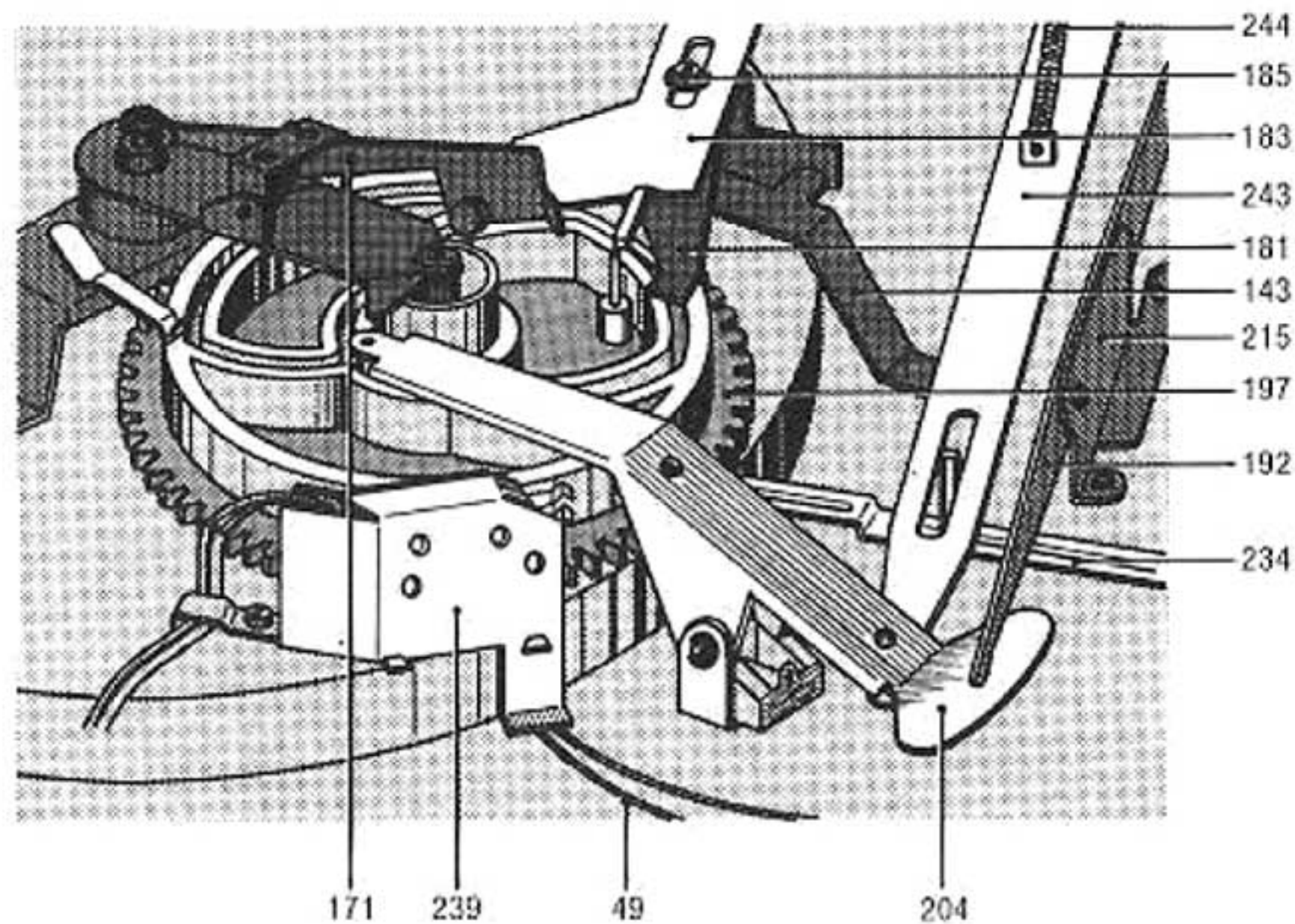

Tonearm movements

A guide groove located on the underside of the main cam (197) controls the automatic lift and set-down of the tonearm as the cam rotates through 360°. Tonearm lift and lowering are controlled by the main lever (204) and the lift screw (229). Horizontal movements are controlled by the main lever (204) and the segment (246). Setting the changer for playback of 7", 10" or 12" discs is done with the indexing lever (24). Setdown points are determined by the eccentric portion of the arm positioning slide (243) and the indexing lever (242).

Horizontal movement of the tonearm is limited by the arm segment striking the arm positioning slide (243). During the change cycle, the main lever (204) raises the arm positioning slide, bringing it within reach of the spring stud. On completion of the change cycle (set-down of the tonearm on the record), the arm positioning slide (243) is again released and returns to its normal position. It thus moves out of reach of the spring stud, permitting the tonearm to move horizontally without hindrance, while playing the record.

Tonearm lift (Cue control)

The tonearm lift permits the tonearm to be set down on the record safely at any desired point except the shut-off area (near the record label).

Pulling the tonearm lift towards the front turns the drive washer (207). This moves the connecting lever (192), main lever (204) and lift screw (229) to raise the tonearm.

After the tonearm is moved (by hand) to the desired spot on the record, the tonearm lift handle is lightly tapped towards the rear

to release the mechanism. The connecting lever (192) and the leaf spring (186) of the main lever are freed, allowing the tonearm to fall. The rate of fall is controlled by silicone grease on the drive washer (207).

The height of the stylus above the record can be varied from zero to about 1/4" by adjusting setscrew (211).

Turning it to the right increases the height, turning it to the left decreases the height.

Fig. 11 Tonearm lift (tonearm raised)

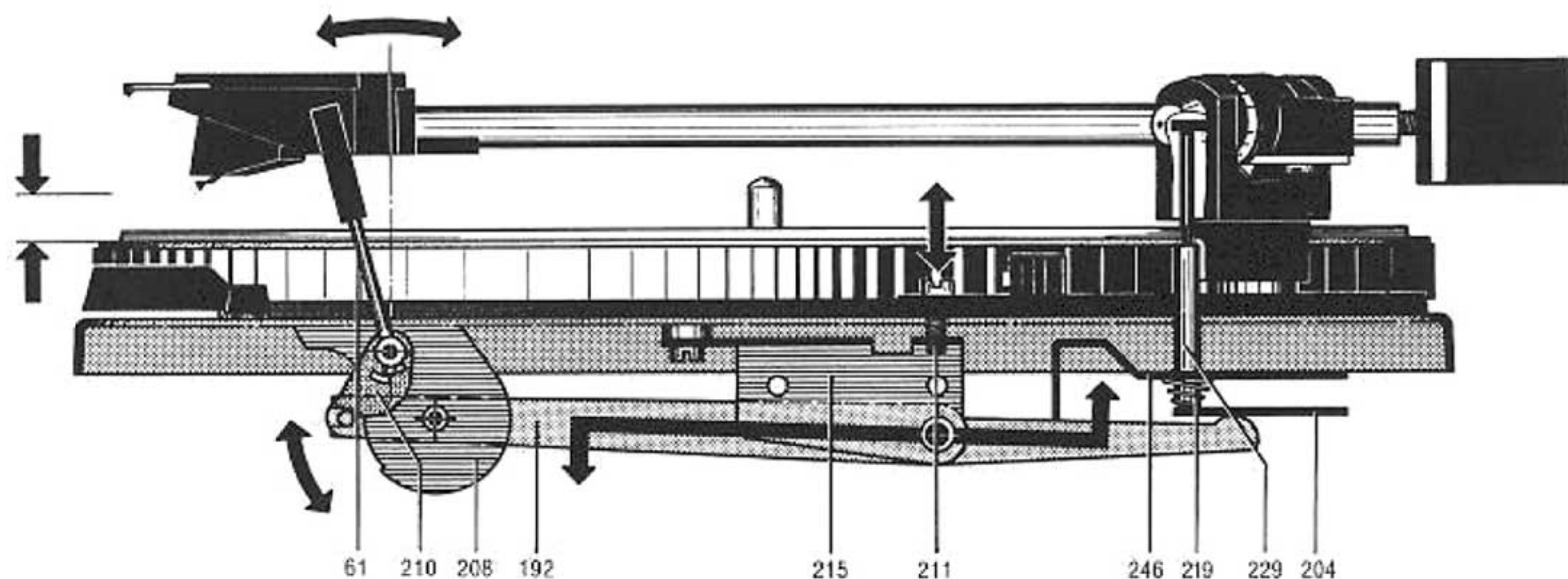

Symptom	Cause	Remedy
Tonearm misses edge of record	a) Set-down incorrectly adjusted b) Record not standard size c) Friction surfaces of tonearm clutch dirty	a) Adjust set-down with a 12" record so that stylus touches record approximately 1/16" inside edge of record. Adjustment will be correct for other sizes b) Use standard records c) Clean clutch surfaces
Tonearm strikes record during change cycle	Tonearm height incorrectly set	Adjust arm height with screw (46). Height is correct when stylus tip is 1/16" to 1/8" above start switch (25) when arm is removed from rest lowered
Tonearm does not move onto record when drop cycle is started	Damping too great, drive washer dirty	Loosen nut (205) and washer (206) and coat both sides evenly with silicone grease, Reassemble and wipe off excess grease
Tonearm lowers too quickly when drop cycle is started	Too little damping	Loosen nut (205) and washer (206) and drive washer (207). Clean thoroughly, Coat both sides evenly with silicone grease, re-assemble and wipe off excess
Tonearm returns to rest immediately after being placed on record manually	Shut-off mechanism has shifted out of position during shipping	Before using changer after moving, run it through start cycle with tonearm locked on rest

Start cycle

Moving the start switch (25) moves the switch lever (181) towards the main cam (197), initiating the following sequence,

- The set screw of the switch lever assembly (181) turns the switch arm (143) mounted on the grooved shaft (185). Via a tension spring, this actuates the rocker assembly (105) and engages the idler (108) between the platter (5) and the motor pulley (120). At the same time, the power switch (141) is actuated by the switch slide (138) through the switch arm, and the turntable begins to rotate.
- The switch lever (181) is brought within reach of the cam follower lever (236), so that it is pushed into the change position after the rotation of the main cam,

Fig. 12 Start position

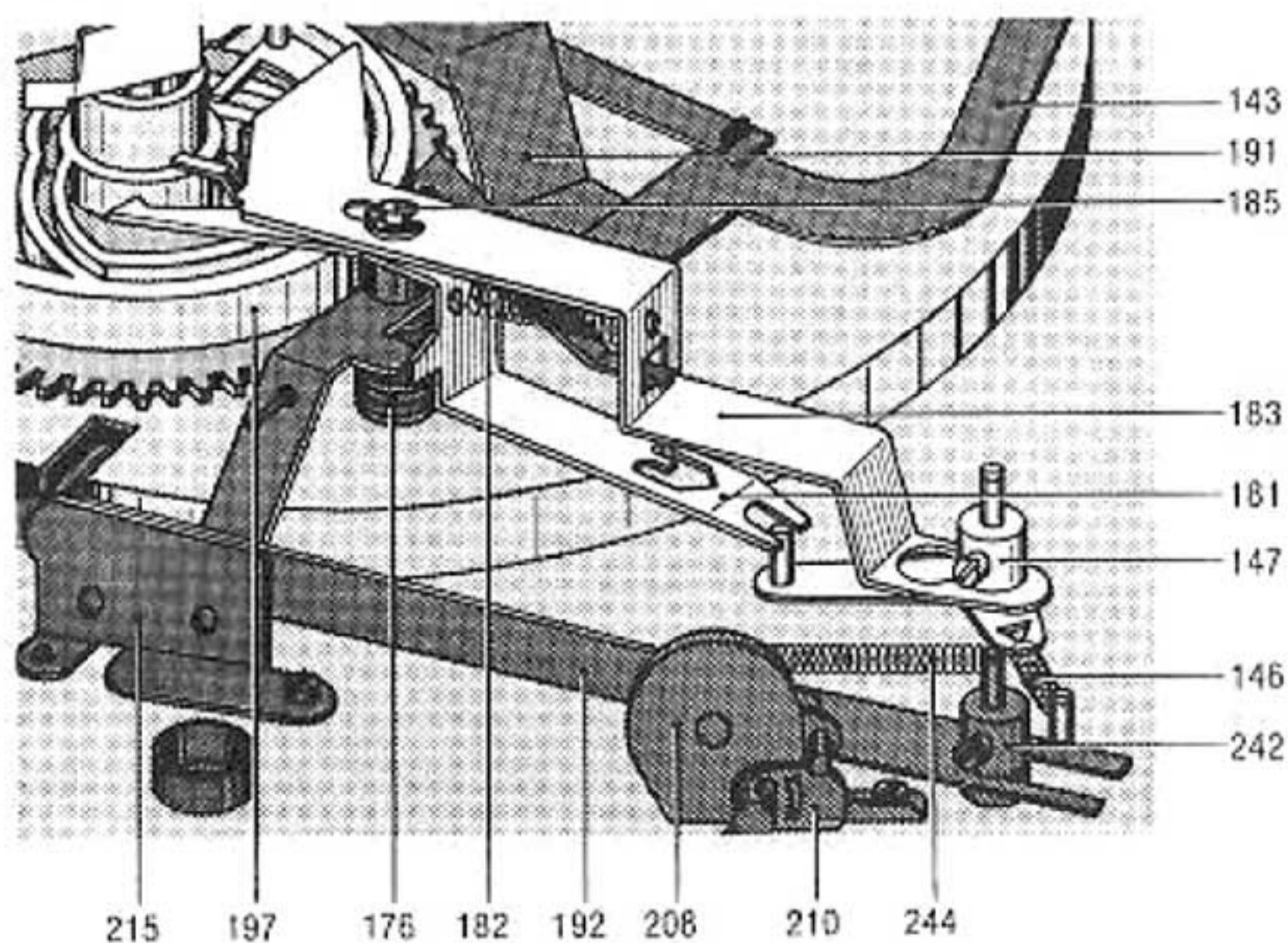
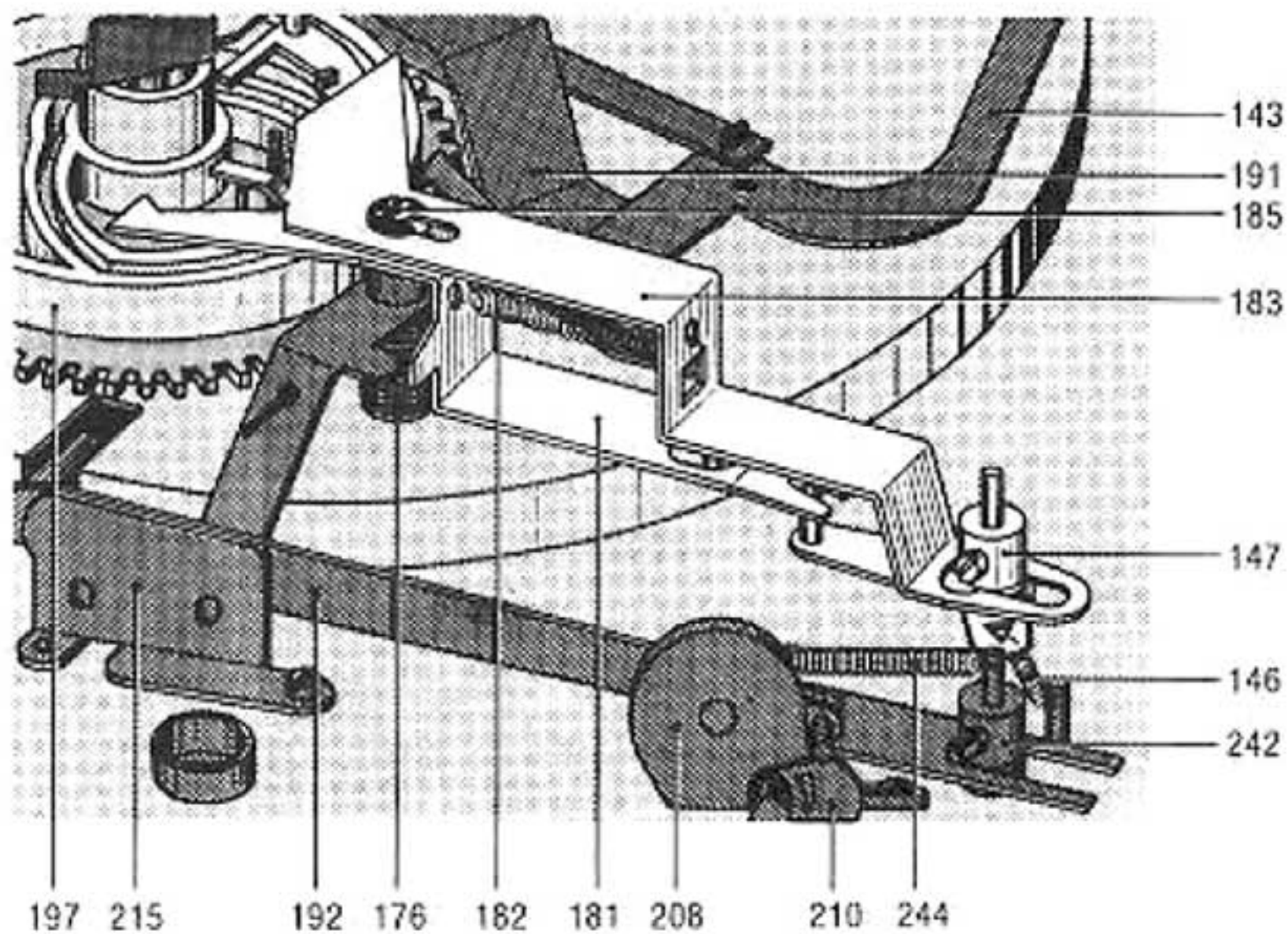

Fig. 13 Stop position



Moving the operating switch also releases the start lever (183), pulling it towards the main cam by means of the tension spring (182). This causes coil spring to bring the shut-off lever (222) within range of the main cam dog. Thus the shut-off lever drives the main cam.

To prevent malfunctioning, the operating switch is locked during the start cycle (that is, while the main cam is turning). Just before the main cam reaches its neutral position (at the end of the change cycle), the start lever is pushed clear of the main cam by the start pin of the main cam. This restores the switch lever and operating switch to their original positions.

After installation and also after moving the changer, the unit should be started with the tonearm locked on the rest. This will automatically re-adjust the shut-off lever, which may have shifted out of position.

Fig. 14 Muting switch

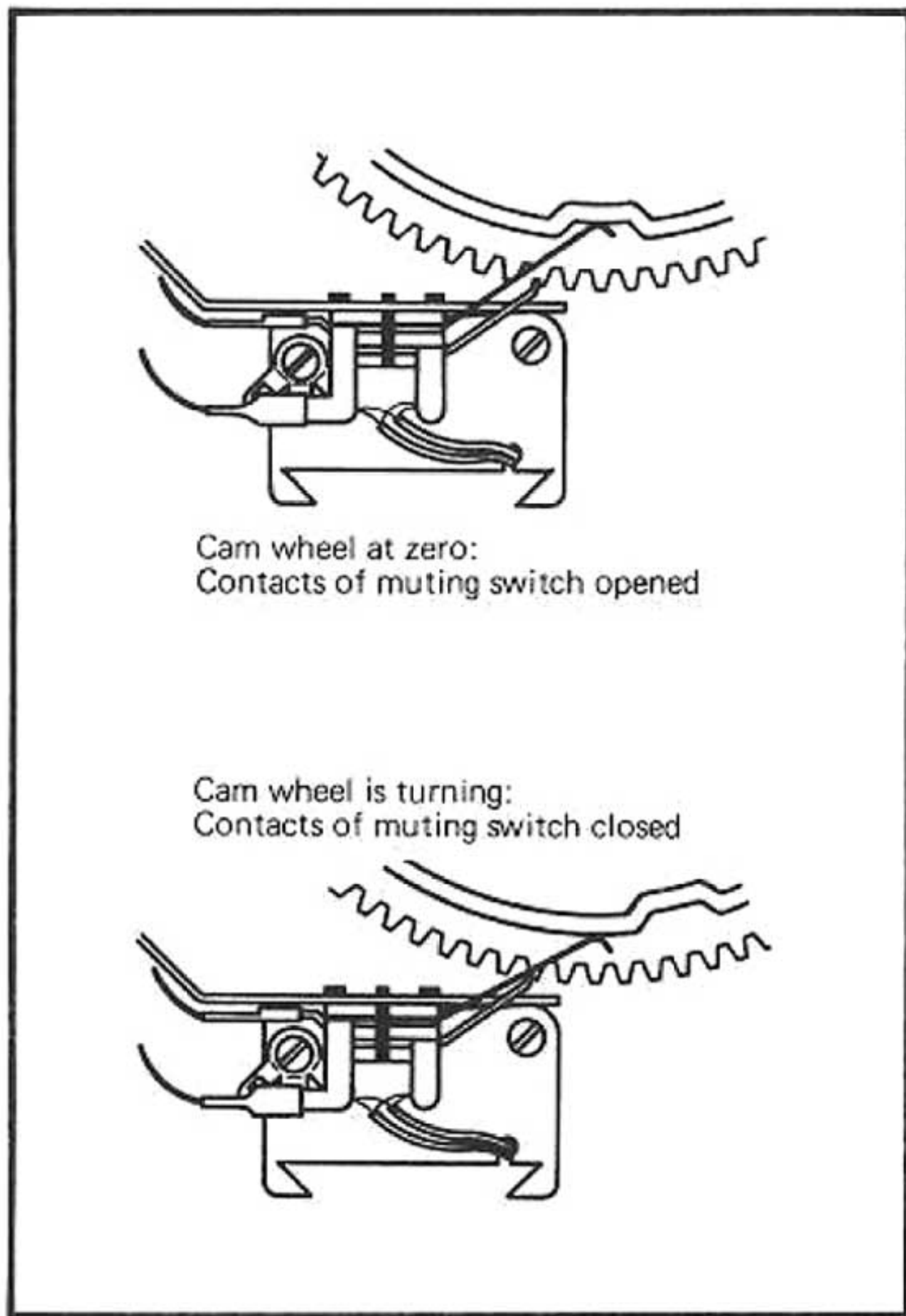

Manual start

When the tonearm (16) is swung inward by hand, the pawl on the switch arm drops into a support on the base plate, holding the switch arm in this position and the idler wheel (108) in contact with the platter. The slide (138) linked with the switch arm actuates the power switch and sets the turntable platter rotating.

On reaching the run-out groove, the tonearm automatically returns to its rest position and the unit shuts itself off. (See shut-off mechanism, next side). However, if the tonearm is lifted off the record manually returned to the rest, the tabs of the arm segment (246) release the pawl. The torsion spring (176) then returns the switch arm to its initial position, opening the power switch and disengaging the idler wheel.

Stop switching

When the operating lever is moved to "stop", the starting lever (183) is pushed forward. As a result the shut-off linkage comes into contact with the main cam. The swinging lever (236) remains in its stop position.

When the tonearm is on its rest and the operating lever is pushed to "stop", the operating lever must not jam.

Muting Switch

To prevent the noises of the change cycle from being sent through the audio system, the apparatus is fitted with a short-circuiting (muting) switch (239). The switch springs for both channels are actuated by the main cam (197). In the tonearm rest position, the muting switch is opened.

Fig. 15 Record drop

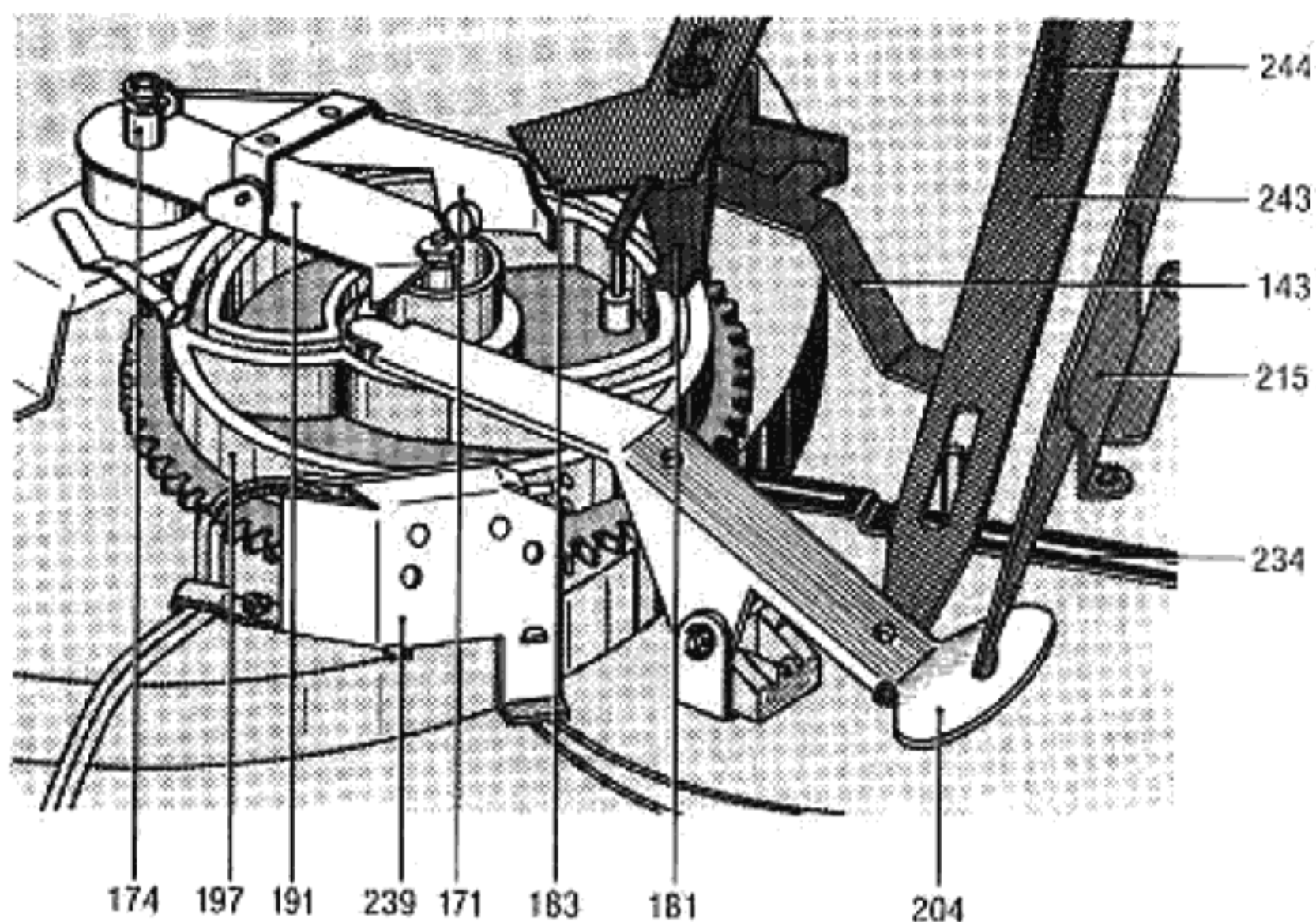

Record drop

Insert the appropriate spindle - AW 3 for standard records (7 mm center hole) or AS 12 for 45 rpm records (38 mm center hole).

Record-drops is initiated by the rotation of cam, whose cam surface guides the cam rocker, pushing the change actuator stud and releasing a record by means of the automatic spindle. The main cam is designed so that a record can drop only when the tonearm is above the tonearm rest and thus out of the reach of the largest possible records (12" diameter).

Fig. 16 Actuating "change" or "shut-off"

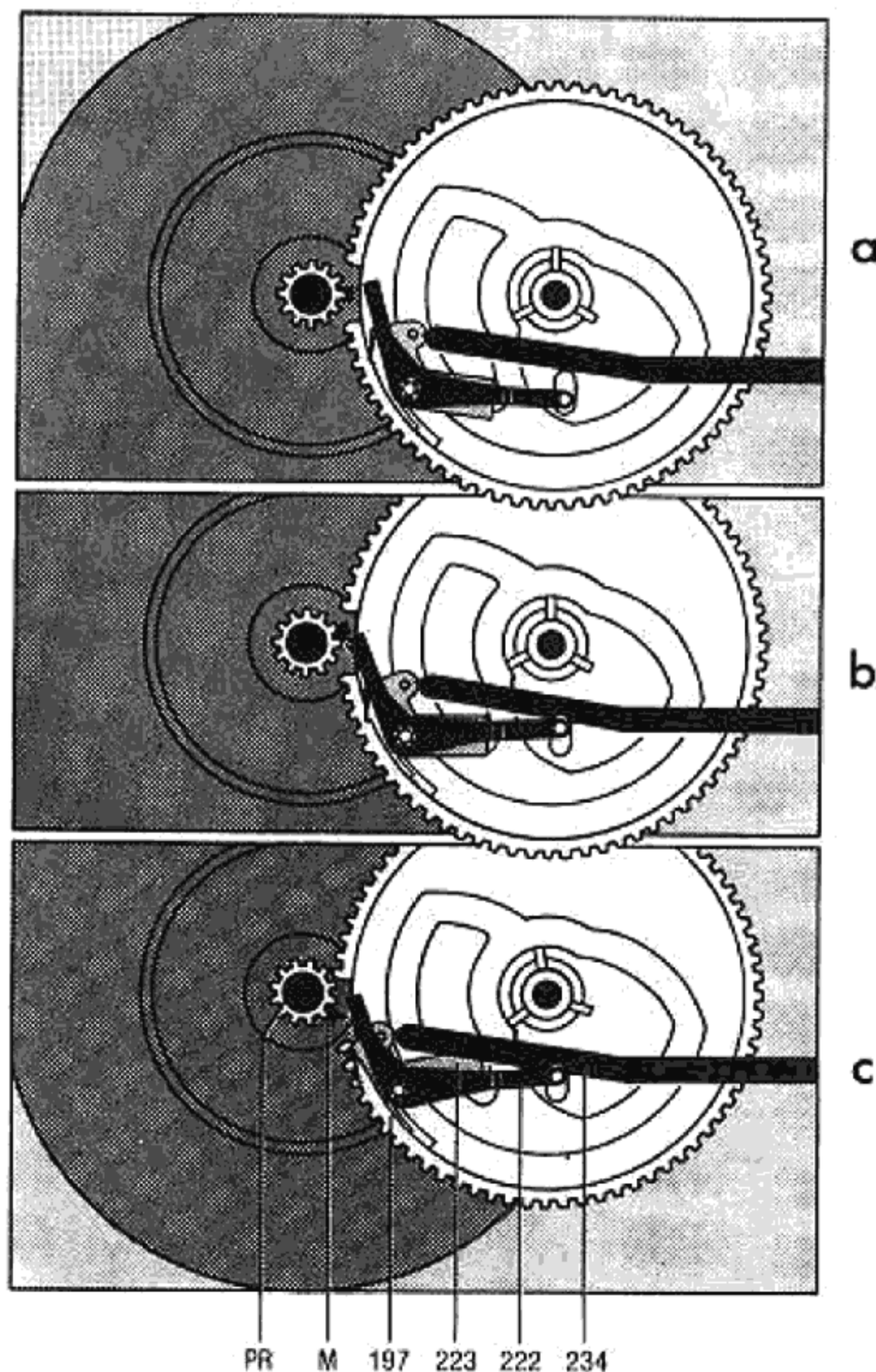

Shut-off and change cycle

The dog (M) on the turntable platter gear (PR) and the shut-off lever (222) actuate both the change cycle at the end of the record as well as the shut-off after the last record in a stack is played.

At the end of a record, the tonearm moves towards the center at an accelerated rate due to the increased pitch of the grooves. This motion carries the shut-off lever (222) towards the dog by means of the shut-off slide (234). The eccentric dog pushed the shut-off lever (232) back at each revolution as long as the tonearm advance is only one normal record groove.

The run-out groove with its steeper pitch moves the shut-off lever against the dog with greater force, engaging the shut-off lever (222) and causing the main cam (197) to be driven out of its neutral position by the turntable platter gear.

Fig. 17 Change cycle

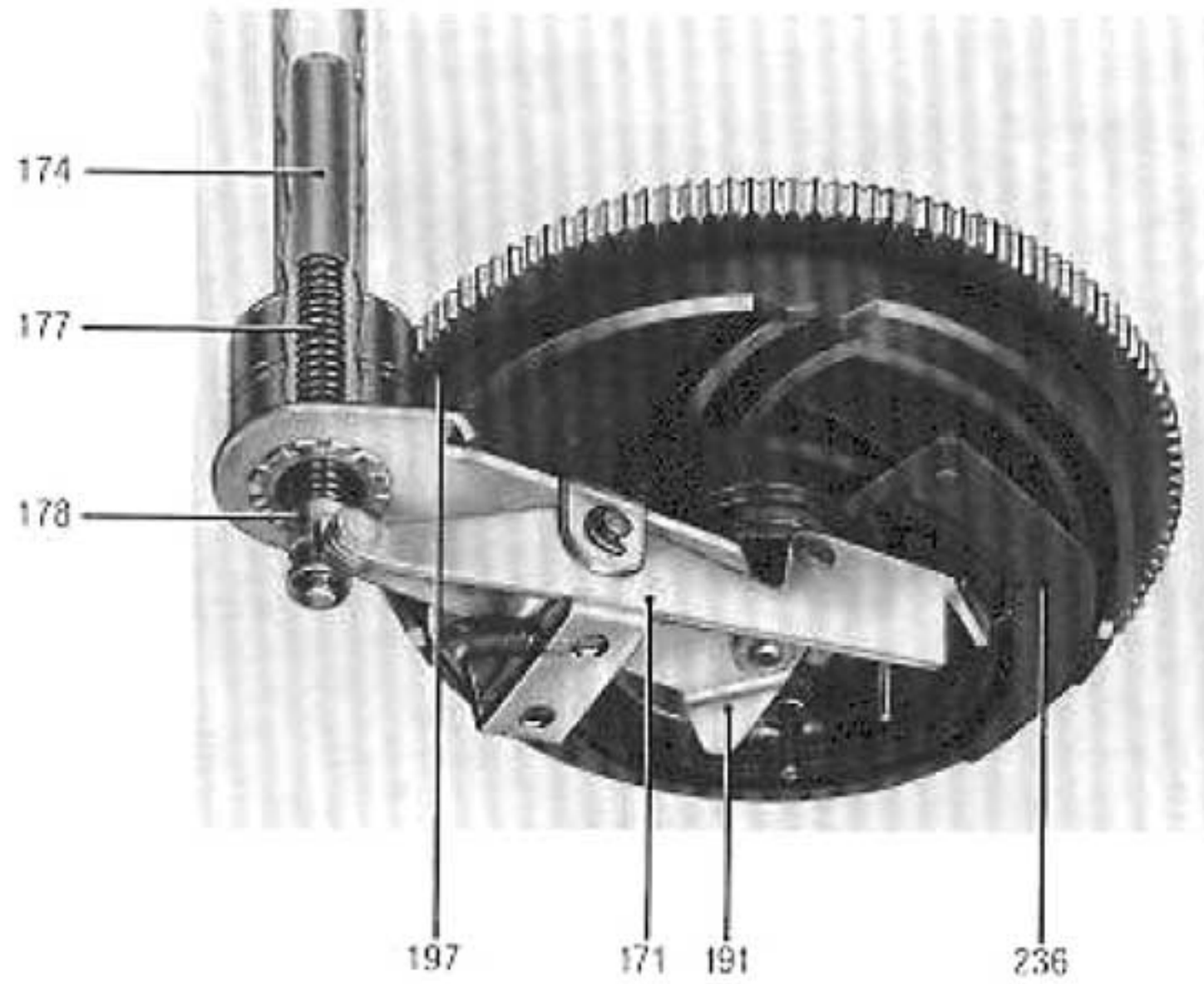

Shut-off mechanism

Shut-off and change functions are determined by the position of the cam follower lever (236). After every start or record-drop, the cam follower lever is brought to its stop position by the main lever (204) (longer end towards the center of the main cam). As the record is dropped the cam follower lever (236) is turned to its start position by the cam rocker (171), so that the tonearm can swing in toward the record and be lowered on to it. If there are no more records on the spindle and the cam rocker cannot turn the cam follower lever, the lever remains in its stop position and allows the tonearm to swing to its rest position.

When the main cam (197) returns to its neutral position, the switch arm (143) drops into a cut-out in the main cam, opening the power switch (141) and disengaging the drive idler (108).

Fig. 18

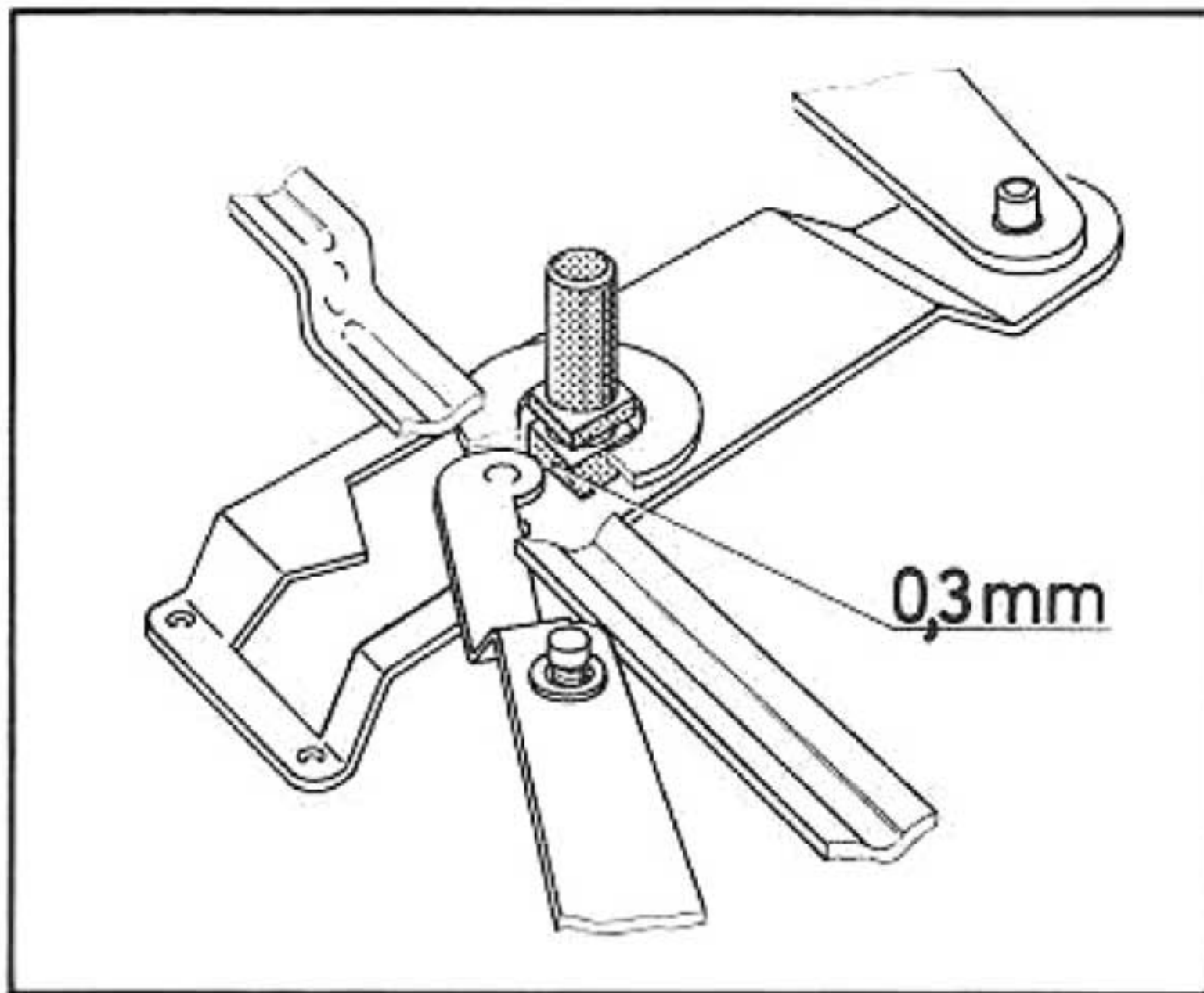

Symptom

Turntable stops after automatic setdown of the tonearm

Cause

- a) Switch arm (143) is not latched by pawl (194)
- b) Power switch opens

Remedy

- a) Loosen screw and turn the short arm piece on the long switcharm piece. Move the tonearm in and turn the main cam to its neutral position and adjust for about 1/64" play between cam and rectangular bolts riveted into the chassis.
- b) As the tonearm moves in, switch slide (138) must over-travel by about 1/64". Its tab must engage the switch (138).

Fig. 19

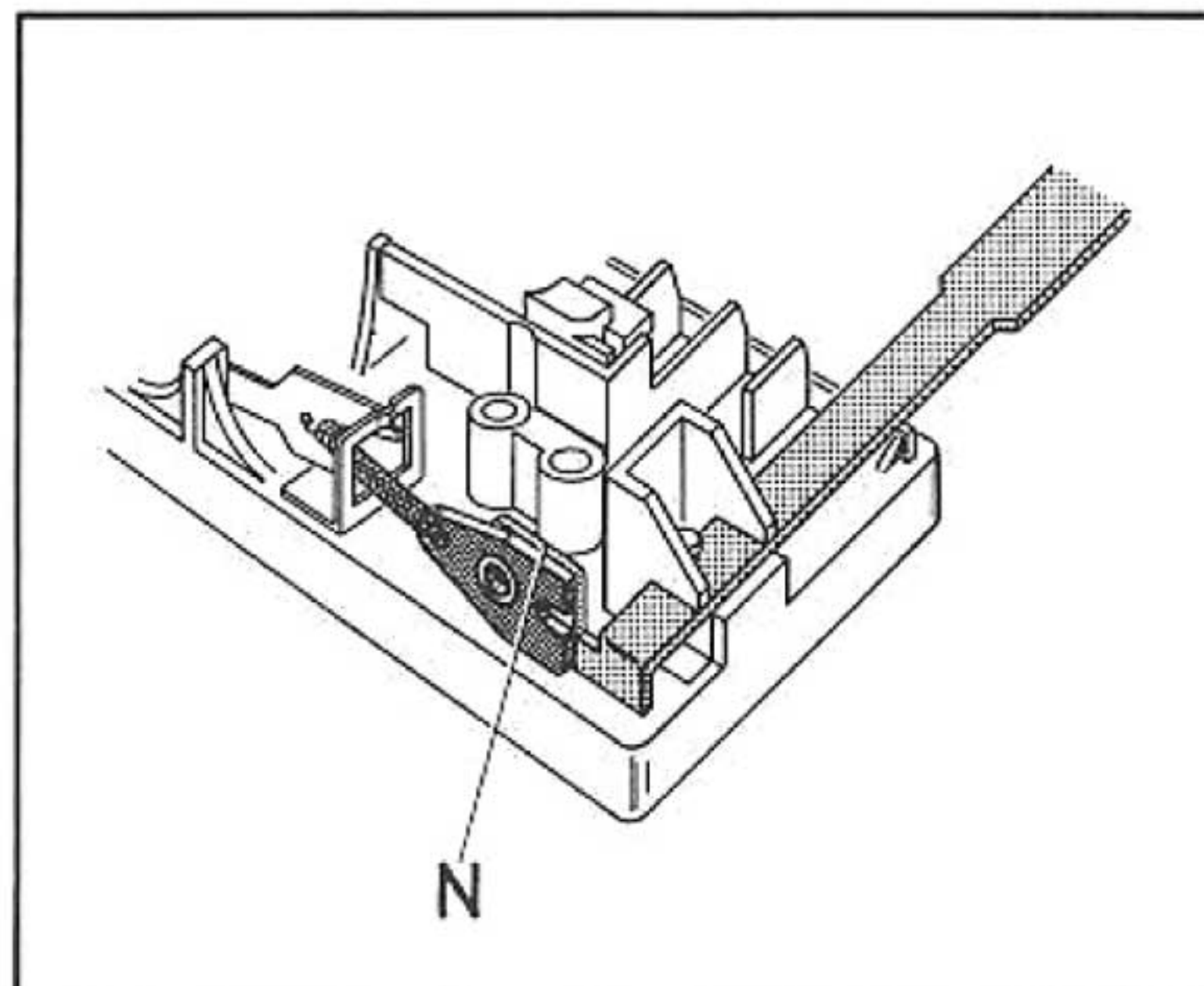

Symptom

Last record keeps repeating

Cause

Defective spindle

Remedy

Replace spindle

Symptom

Record does not drop when unit is switched to "start"

Cause

Inadequate engagement between change lever and cam rocker (171)

Remedy

Adjust clearance between change lever and cam rocker to 1/64" minimum with apparatus in "start" position.

Fig. 20

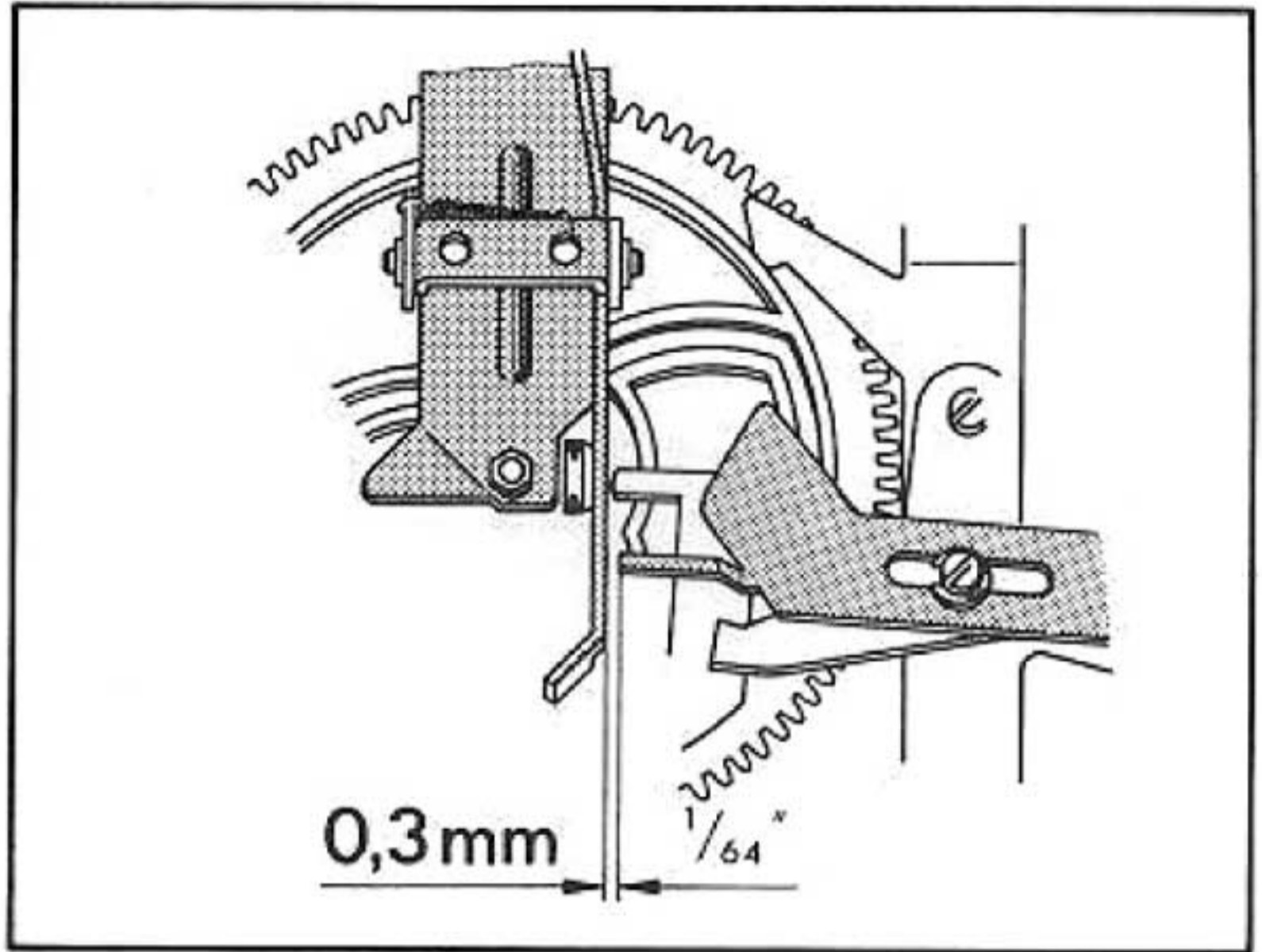

Fig. 21

Symptom

Record drops when unit is switched to "stop"

Cause

Cam rocker (171) not caught by start lever

Remedy

Adjust cam rocker so that at the conclusion of the "stop" function the start lever runs about 1/16" under the follower.

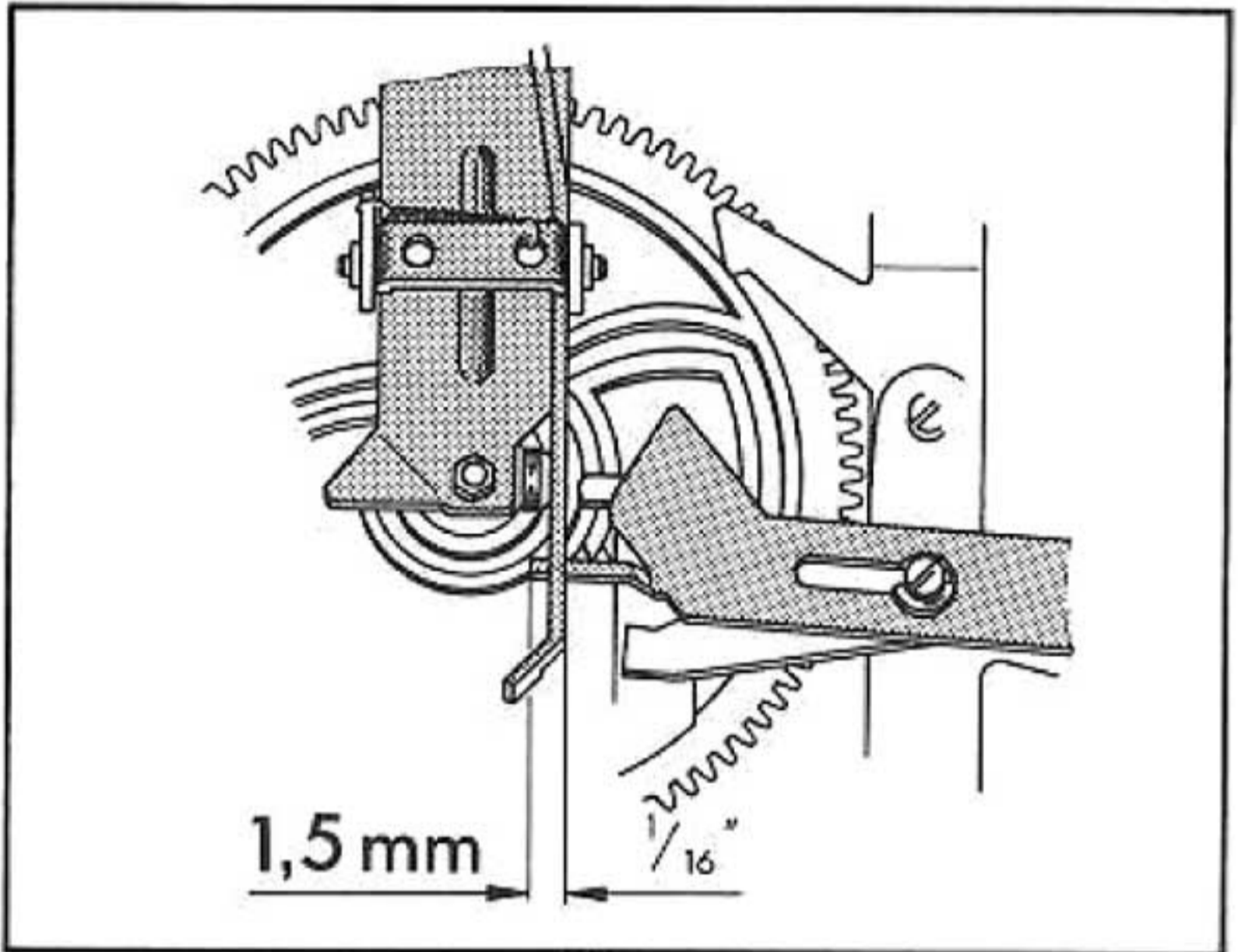

Fig. 22

Symptom

Records do not drop

Cause

Cam rocker (171) has too little force (travel)

Remedy

Re-adjust eccentric so that when the three supports in the automatic spindle are held in and the main cam is at its neutral, pressing the change screw moves the support about 1/64".

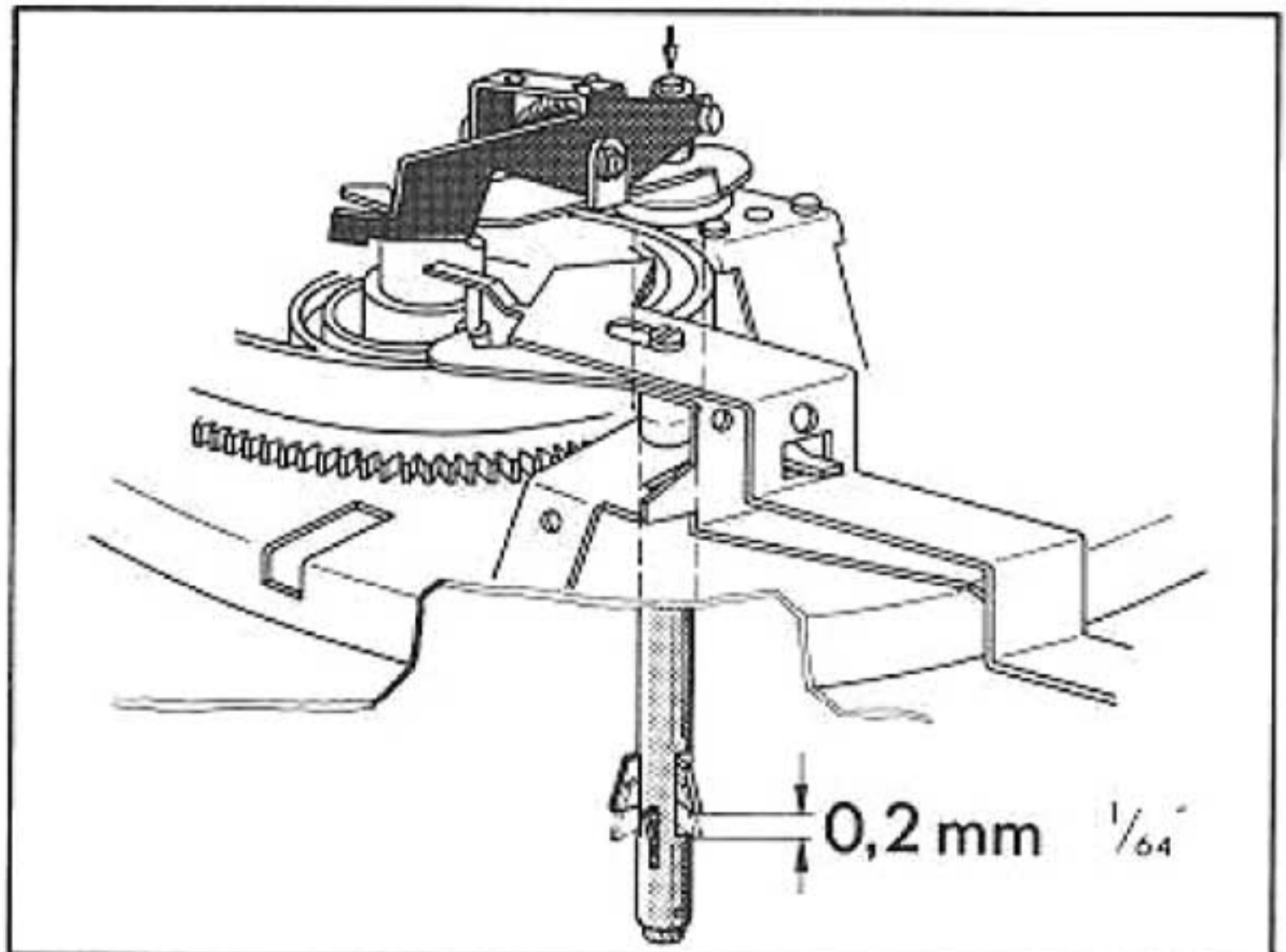
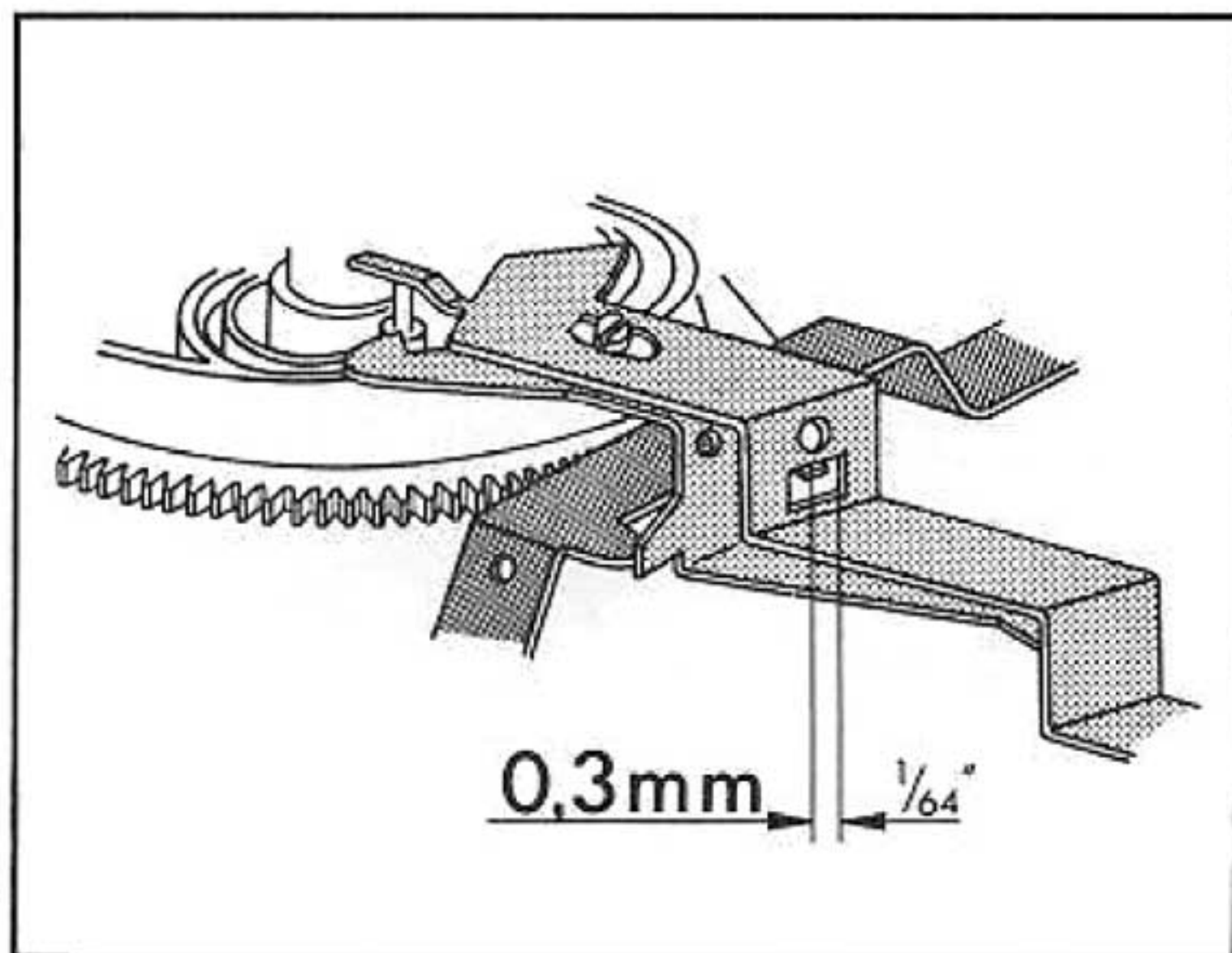

Fig. 23



Symptom

Switch latches into "stop" position when tonearm is at rest.

Cause

Too much clearance between tab on switch arm (143) and start lever (183)

Remedy

Adjust tab on switch arm so that it clears start lever by 1/64" when main cam is in neutral position.

Symptom	Cause	Remedy
Tonearm moves with stylus force and anti-skating force at zero: a) outward; b) inward	a) Anti-skating out of adjustment b) Too-taut tonearm leads produce a twisting force	a) Adjust skating lever so that horizontal movement of tonearm causes no movement of anti-skating spring. b) Allow some slack in tonearm leads
During change, stop and start operations, noises from the mechanism can be heard in system speaker	Muting switch misadjusted, Distance between contact springs and shorting contact is too great	Bend contacts so that, in the neutral position of the main cam the spacing between contacts is about 0.02 inch. Clean contacts
No sound	Spacing too small	See above
Motor will not shut off when tonearm is on arm rest	Capacitor across power switch is shorted	Replace capacitor (0.1 μ F, 700 V)
Acoustic feedback	a) Chassis parts (for example leads) are touching base cut-out b) Connecting cables are too taut	a) Correct cut-out according to enstructions supplied with unit. Move cables b) Allow more slack in cables

Replacement parts

Pos.	Part.No.	Description	Quantity
1	215 470	Automatic spindle AS 12	1
2	213 895	Changing spindle AW 3	1
3	201 452	Facing ring 170 mm \varnothing	1
4	218 667	Turntable mat complete, with facing ring 170 mm \varnothing	1
5	218 666	Turntable complete, with turntable mat and facing ring 170 mm \varnothing	1
6	219 952	Speed change lever, left	1
7	219 965	Speed regulator knob complete	1
8	225 590	Blind (inch)	1
9	223 010	Chassis complete	1
10	214 210	Shipping screw assembly complete	2
11	220 213	Centering disc for single discs	1
12	200 709	Single play spindle	1
13	214 054	Washer	1
14	200 543	Refining ring	1
15	225 591	Tonearm complete	1
16	223 011	Tonearm rest assembly complete	1
17	210 362	Hex nut BM 3	2
18	223 001	Tonearm head complete	1
19	201 132	Lift	1
20	210 182	Lockwasher	1
21	210 630	Washer 4.2/8.0/0.5 St	1
22	210 197	"C" clip G 4 x 0.8	1
23	215 430	Cartridge mount TK 14	1
24	219 954	Switch lever, right	2
25	219 954	Switch lever, right	2
26	210 816	Machine screw M 4 x 4	1
27	217 374	Centering screw	1
28	210 366	Hex nut BM 4	6
29	210 362	Hex nut BM 3	2
30	223 051	Bearing race complet	2
	211 710	Steel balls 3 mm \varnothing	10
31	200 579	Spring mounted footing (1 set = 3 pieces)	1
32	210 366	Hex nut BM 4	6
33	200 721	Threaded piece	3
34	200 720	Compression spring	3
35	200 723	Rubber insert isolation mount	3
36	200 722	Steel cup	3
37	210 624	Washer 4.2/7.0/0.3 St	4
38	201 632	Rubber washer	2
39	200 713	Washer	2
40	200 712	Spring cup	2
41	200 711	Spring clip	2
	210 366	Hex nut BM 4	4
42	210 624	Washer 4.2/7.0/0.3 St	4
43	200 715	Compression spring	2
44	217 438	Threaded pin	1
45	200 829	Stop nut	1
46	218 636	Set screw	1
47	207 839	Damping ring	1
48	210 146	"C" washer 3.2	5
49	223 005	Contact plate complete	1
50	225 104	Weight complete	1
51	225 317	Threaded pin	1
52	223 003	Tonearm bearing complete	1
53	217 894	Spring barrel complete	1
54	221 510	Stop plate	1
55	210 487	Machine screw M 3 x 10	1
56	223 004	Tonearm bearing support	1
57	216 504	Indicator	1
58	217 436	Bearing screw complete	1
59	221 926	Turn-knob	1
60	225 103	Dress-up plate complete	1
61	216 881	Arm lift lever complete	1
62	210 353	Hex nut BM 2	1
63	217 905	Damping piece	1
64	213 260	Pin 2 x 6	4
65	214 047	Special screw (pierced)	2
	214 211	Spezial screw (threaded)	2

Fig. 24 Exploded view, parts above chassis

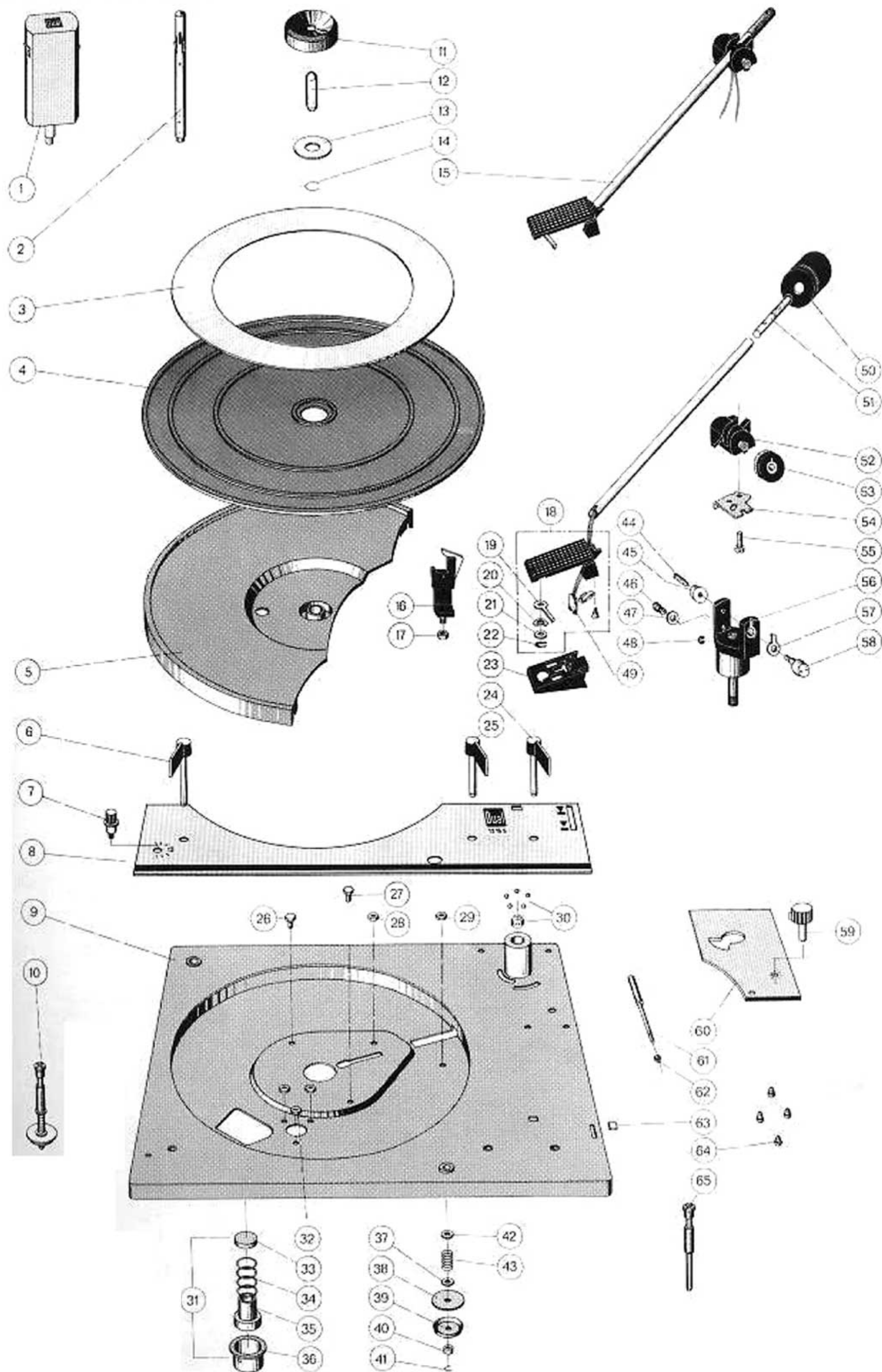
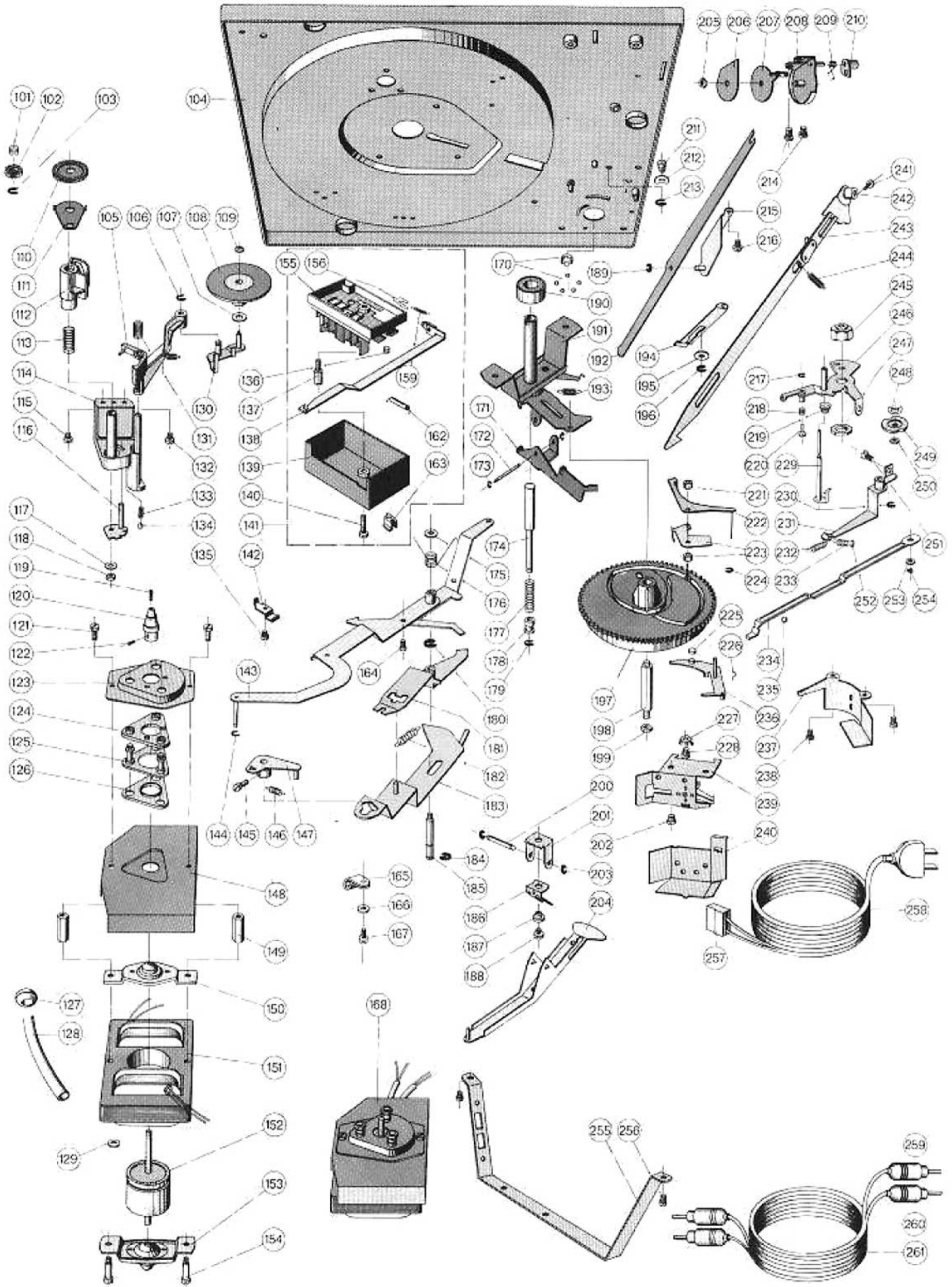

Fig. 25 Exploded view, parts below chassis



Pos.	Part.No.	Description	Quantity
101	217 376	Compression spring	1
102	217 026	Cam wheel	1
103	210 146	"C" washer 3.2	5
104	223 010	Chassis complete	1
105	217 234	Switch lever complete	1
106	210 146	"C" clip 3.2	5
107	200 110	Washer	1
108	212 117	Idler wheel complete	1
109	200 633	Lockwasher	1
110	217 027	Speed regulator wheel	1
111	217 233	Speed regulator detent	1
112	217 028	Switching segment	1
113	216 736	Compression spring	1
114	216 558	Support complete	1
115	210 475	Machine screw AM 3 x 5	12
116	217 239	Groove detent complete	1
117	210 642	Washer 4.2/10.0/1.5 St	1
118	210 361	Hex nut M 3	1
119	217 751	Threaded pin M 2.6 x 8	1
120	220 970	Motor pulley 50 cycles	1
	220 971	Motor pulley 60 cycles	1
121	210 509	Machine screw AM 3.5 x 8	2
122	210 220	Threaded pin M 2.6 x 3.5	1
123	204 669	Dress-up plate	1
124	221 386	Isolation mount plate	1
125	215 846	Mounting bracket complete	1
126	221 385	Isolation washer lower	1
127	209 939	Sleeving	1
128	217 727	Isolation sleeve	1
129	220 807	Washer 4.5/9/1.2 F	1
130	217 244	Idler arm complete	1
131	216 737	Compression spring	1
132	210 475	Machine screw AM 3 x 5	12
133	218 629	Compression spring	1
134	209 358	Steel ball 4 mm Ø	1
135	210 475	Machine screw AM 3 x 5	12
136	218 986	Roller for switch slide	1
137	214 181	Screw bolt	1
138	213 970	Switch slide complete	1
139	214 207	Cover for power switch less voltage selector ...	1
140	210 492	Machine screw AM 3 x 15	1
141	214 205	Power switch complete less voltage selector	1
142	200 447	Cable clamp	1
143	217 889	Switch arm complete	1
144	210 145	"C" washer 2.3	9
145	210 475	Machine screw AM 3 x 5	12
146	216 777	Tension spring	1
147	216 773	Switch-on lever	1
148	204 665	Shield	1
149	200 167	Bearing spacer	2
150	204 686	Motor bearing top complete	1
151	217 591	Stator 110/220 V complete	1
152	204 687	Rotor complete	1
153	204 685	Motor bearing lower complete	1
154	204 468	Screw bolt	2
155	214 206	Switch plate complete less voltage selector	1
156	213 966	Snap spring	1
159	213 968	Tension spring	1
162	203 725	Capacitor	1
163	213 978	Locking device small	1
	213 979	Locking device large	1
164	210 475	Machine screw AM 3 x 5	12
165	220 152	Plastic clamp	1
166	210 586	Washer 3.2/7.0/0.5 St	2
167	210 475	Machine screw AM 3 x 5	12
168	220 973	Motor 110/220 V complete	1
170	223 051	Bearing race complete	2
171	213 922	Cam rocker complete	1
172	217 813	Shaft	1
173	210 145	"C" washer 2.3	9
174	213 918	Change actuator complete	1
175	210 586	Washer 3.2/7.0/0.5 St	2
176	213 940	Torsion spring	1
177	213 920	Compression spring	1
178	213 921	Bushing	1

Pos.	Part.No.	Description	Quantity
179	210 145	"C" washer 2.3	9
180	210 147	"C" washer 4	3
181	218 538	Switch lever complete	1
182	200 103	Tension spring	1
183	217 258	Start lever complete	1
184	210 147	"C" washer 4	3
185	217 334	Grooved shaft	1
186	201 186	Leaf spring	1
187	200 458	Spacer	1
188	210 480	Machine screw AM 3 x 6	1
189	210 145	"C" washer 2.3	9
190	200 554	Ball bearing	1
191	214 201	Bearing support complete	1
192	217 300	Connecting lever	1
193	213 925	Tension spring	1
194	213 942	Latch complete	1
195	202 043	Washer 5.8/12.0/0.5 St	1
196	210 146	"C" washer 3.2	5
197	220 332	Cam wheel complete	1
198	200 519	Bearing post	1
199	210 366	Hex nut BM 4	6
200	200 528	Shaft	1
201	201 185	Bearing support	1
202	210 475	Machine screw AM 3 x 5	12
203	210 145	"C" washer 2.3	9
204	201 094	Main lever complete	1
205	210 366	Hex nut BM 4	6
206	201 195	Cover washer	1
207	217 290	Drive washer complete	1
208	217 286	Support bracket assembly	1
209	217 296	Torsion spring	1
210	221 527	Drive cam	1
211	220 167	Set screw	1
212	210 187	Bowed lockwasher	1
213	210 147	"C" washer 4	3
214	210 469	Machine screw AM 3 x 3	2
215	217 297	Bearing support complete	1
216	210 511	Machine screw AM 4 x 4	1
217	210 143	"C" washer 1.5	1
218	201 174	Compression spring	1
219	221 525	Conical spring	1
220	200 686	Spring pin	1
221	220 235	Stop nut	1
222	220 232	Shut-off lever complete	1
223	222 690	Friction plate complete	1
	221 935	Bushing	1
224	210 145	"C" washer 2.3	9
225	200 650	Sleeve	1
226	200 522	Snap spring	1
227	211 614	Solder lug	1
228	210 475	Machine screw AM 3 x 5	12
229	224 375	Lift rod complete	1
230	210 146	"C" washer 3.2	5
231	222 691	Skating lever complete	1
232	217 948	Tension spring	1
233	218 591	Tension spring	1
234	200 688	Shut-off slide	1
235	209 358	Steel ball 4 mm Ø	2
236	214 203	Cam follower lever complete with sleeve	1
237	217 285	Cover plate	1
238	210 475	Machine screw AM 3 x 5	12
239	207 447	Muting switch complete	1
240	201 240	Motor shield	1
241	218 583	Machine screw M 3 x 4	1
242	217 264	Record size selector left complete	1
243	217 276	Arm positioning slide complete	1
244	200 453	Tension spring	1
245	221 518	Stop nut	1
246	223 000	Segment complete	1
247	221 524	Hex nut	1
248	216 867	Bowed lockwasher	1
249	220 899	Cam washer	1
250	210 361	Hex nut M 3	1
251	221 260	Set screw	1
252	201 184	Set washer	1
253	201 187	Friction disc	1

Pos.	Part.No.	Description	Quantity
254	210 145	"C" washer 2.3	9
255	217 759	Stand complete with phono jacks	1
256	210 475	Machine screw AM 3 x 5	12
257	209 475	Inner casing for AMP-plug	1
258	207 311	Power cable complete with ground connection, 4pole AMP plug casing and U.S. type plug	1
259	209 426	Phono plug, black	2
260	209 425	Phono plug white	2
261	207 299	Audio cable complete, with phono plugs	1
**	201 229	Cover pin	1
**	214 120	Mounting hardware	1
**	213 243	Stroboscope disc 60 Hz	1
**	214 219	Packing carton complete	1
**	225 336	Operating instructions 1215 S	1
**	225 335	Mounting instructions	1
**	214 048	Mounting gauge for pick-up system	1

Alteration reserved
* * Not illustrated

Lubrication

All bearings and sliding points have been properly lubricated during assembly. Re-lubrication is normally not necessary for about two years since all important bearings are provided with oil retainers and sintered bearings.

Lubrication should be applied sparingly. It is of primary importance that no oil grease should get onto the friction surfaces of the drive wheel, motor pulley or turntable, to avoid slippage. For the same reason, avoid touching these parts.

Use the following lubricants:



Adhesive oil,
Renotac No. 342



BP oil, Super Visco-
static 10 W/30



Shell Alvanis No. 2

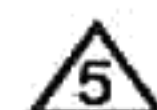

Isoplex PDP 40



Wacker siliconoil
AK 500 000

Fig. 26 Chassis, viewed from above

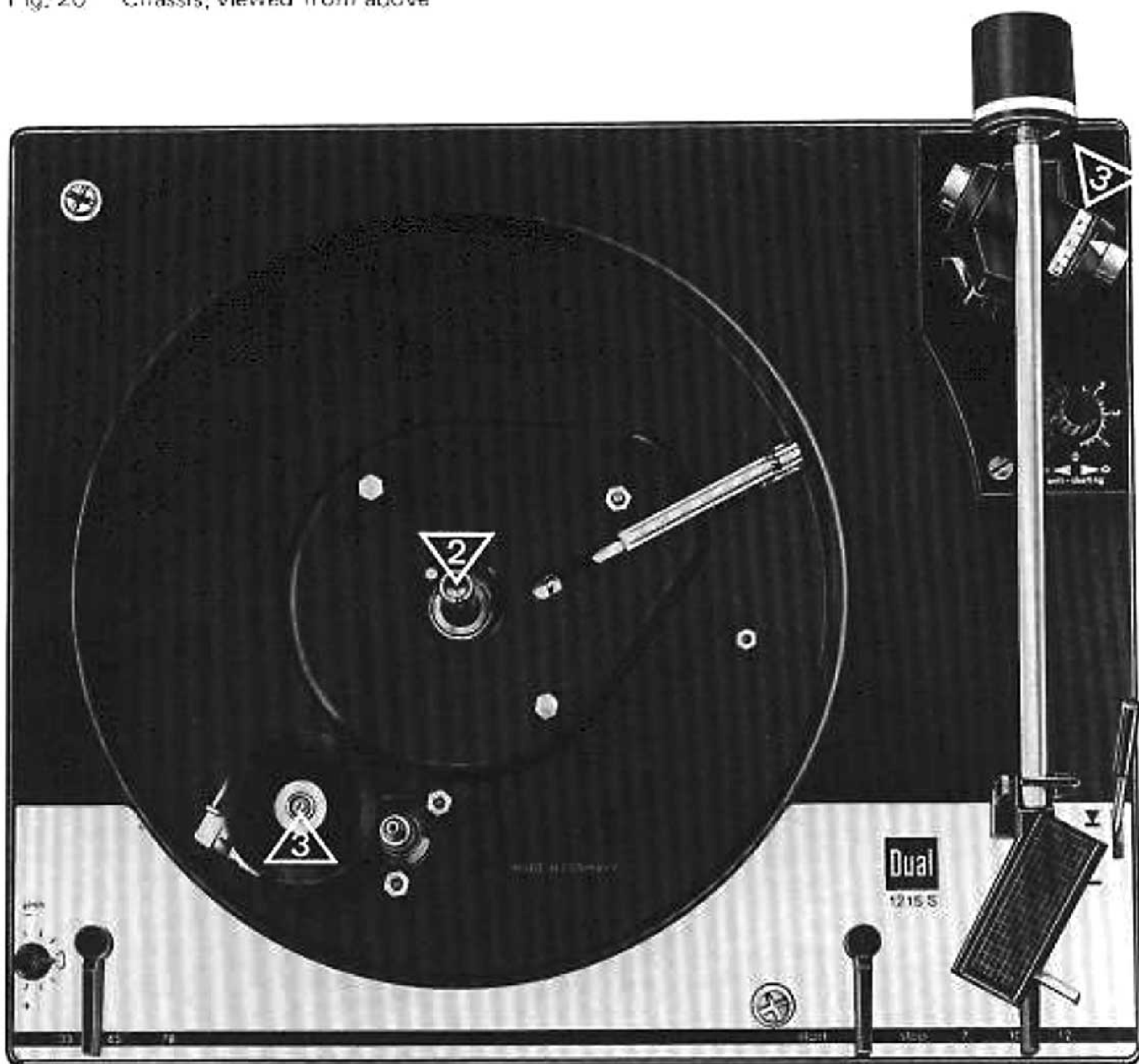

Fig. 27 Chassis, viewed from below





Dual Gebrüder Steidinger · 7742 St. Georgen/Schwarzwald